

MARANTZ DESIGN AND SERVICE

Using superior design and selected high grade components, MARANTZ Company has created the ultimate in stereo sound. Only original MARANTZ parts can insure that your MARANTZ product will continue to perform to the specifications for which it is famous.

Parts for your MARANTZ stereo are generally available within 72 hours throughout the nation via a toll-free line to our National Parts Depot in California. The sales professionals who take your call immediately refer to their own desk top computer terminal and can quickly determine the availability and price information you require. If, for some reason, your order should exceed our available stock, we usually can instantly provide an alternate replacement part or current delivery information. When the order is placed and confirmed, the computer simultaneously generates "hard copy" orders at the distribution center. As hard copies come directly from the computer to the national parts depot, your requested stock is assembled and prepared for shipment and placed on the first available carrier for delivery to you.

ORDERING PARTS

Phone orders will eliminate mail delays, and we encourage the use of this method. If you order by mail, use MARANTZ parts order forms which are available from our National Parts Depot located at the following address:

SUPERSCOPE NATIONAL PARTS DEPARTMENT
20525 Nordhoff Street
Chatsworth, California 91311
Phone: 1-800-423-5108
1-213-998-9333

The following information must be supplied to eliminate delays in processing your order:

1. Complete address.
2. Complete part numbers.
3. Complete description of parts.
4. Model number for which part is required (indicate MARANTZ).
5. Account number (for account customers only).

Direct consumers will be provided with the current retail price quotation on available parts in order to advise them of the cost of the parts and shipping.

OVERSEAS PARTS ORDERING

Parts may also be ordered from the following overseas addresses:

CANADA

Superscope Canada, Ltd.
3710 Nashua Drive
Mississauga
Ontario, Canada L4V1M5

AUSTRALIA

Superscope (Australasia) Pty., Ltd.
32 Cross Street (P.O. Box 604)
Brookvale 2100 N.S.W.
Australia

JAPAN

Marantz Japan, Inc.
3622 Kamitsuruma
Sagamihara Shi
Kanagawa, Japan

EUROPE

Superscope Europe, S.A.
Avenue Leopold III, 2
7120 Peronnes-Lez-Binche
Belgium

Marantz France
Rue Louis Armand 9
92600 Asnieres
Hauts-de-Seine
France

Marantz Audio U.K. Ltd.
London Road, 203
Staines
Middlesex
England

Superscope GmbH
Max-Planck-Strasse 22
D-6072 Dreieich 1
West Germany

All of the above locations are fully equipped to take care of your total service needs. Because various countries have differing configuration requirements, it is necessary that you contact the service facility in your particular country. In the event that there is no service location listed for your country, please contact the nearest facility for the necessary assistance.

marantz
We sound better.

TABLE OF CONTENTS

Section	Title	Page
1.	P.W. BOARDS	3
2.	TEST EQUIPMENT REQUIRED FOR SERVICING	4
3.	ALIGNMENT PROCEDURES	5
3.1	FM Alignment Procedures	5
3.2	Multiplex Alignment Procedures	6
3.3	AM Alignment Procedures	6
3.4	Audio Alignment Procedures	7
4.	VOLTAGE CONVERSION	7
5.	DIAGRAMS	8
5.1	Block Diagram	8
5.2	Tuner/Phono Board Schematic Diagram and Component Locations - P100	10
5.3	Power Amp Board Schematic Diagram and Component Locations - P700	12
5.4	Power Supply Board Schematic Diagram and Component Locations - P800	12
5.5	Tone Amp Board Schematic Diagram and Component Locations - PE00	13
5.6	Volume Board Schematic Diagram and Component Locations - PG00	13
5.7	Power LED Meter Amp Board Schematic Diagram and Component Locations - PK02	13
5.8	Power LED Meter Board Schematic Diagram and Component Locations - PK01	14
5.9	Voltage Amp Board Schematic Diagram and Component Locations - PN00	14
5.10	Switch Board Schematic Diagram and Component Locations - PS00	14
5.11	Speaker Switch Board Schematic Diagram and Component Locations - PT00	15
5.12	Tape Input Board Component Locations - PV00	15
5.13	Headphone Board Schematic Diagram and Component Locations - PW00	15
5.14	Meter Board Schematic Diagram and Component Locations - PX00	15
5.15	Stereo LED Board Schematic Diagram and Component Locations - PY00	15
5.16	Dial Pointer Lamp Board Schematic Diagram and Component Locations - PZ00	15
6.	EXPLODED VIEWS AND PARTS LIST	16
6.1	[C01-99] Front Panel	16
6.2	[C02-99] Top Cover	17
6.3	[C03-99] Rear Panel	18
6.4	[P01-99] Front Chassis and General Parts	19
6.5	[P02-99] Chassis and Other Parts	20
6.6	[H01-99] Packing Materials	22
6.7	Electrical Parts	23
7.	TECHNICAL SPECIFICATIONS	30

MODEL SR-6000 STEREOPHONIC RECEIVER



INTRODUCTION

This service manual was prepared for use by Authorized Warranty Stations and contains service information for Marantz Model SR-6000 Stereophonic Receiver.

Servicing information and voltage data included in this manual are intended for use by the knowledgeable and experienced technician only. All instructions should be read carefully. No attempt should be made to proceed without a good understanding of the operation of the receiver.

The parts list furnishes information by which replacement parts may be ordered from the Marantz Company. A simple description is included for parts which can usually be obtained through local suppliers.

1. P.W. BOARDS

As can be seen from the circuit diagram the chassis of Model SR-6000 consists of the following units. Each unit mounted on a printed circuit board is described within the square enclosed by a bold dotted line on the circuit diagram.

1. Tuner/Phono mounted on P.W. Board P100
2. Power Amp mounted on P.W. Board P700
3. Power Supply mounted on P.W. Board P800
4. Tone Amp mounted on P.W. Board PE00
5. Volume mounted on P.W. Board PG00
6. Power LED Meter mounted on P.W. Board PK01
7. Power LED Meter Amp
. mounted on P.W. Board PK02
8. Voltage Amp mounted on P.W. Board PN00
9. Switch mounted on P.W. Board PS00
10. Speaker Switch mounted on P.W. Board PT00
11. Tape Input mounted on P.W. Board PV00
12. Headphone mounted on P.W. Board PW00
13. Meter mounted on P.W. Board PX00
14. Stereo LED mounted on P.W. Board PY00
15. Dial Pointer Lamp mounted on P.W. Board PZ00

NOTE ON SAFETY: THE PARTS MARKED WITH  ARE IMPORTANT PARTS ON THE SAFETY. PLEASE USE THE PARTS HAVING THE DESIGNATED PARTS NUMBERS WITHOUT FAIL.

FTZ REGULATION

Instruction for the use in the range other than specified in FTZ codes.

Achtung für die Leute, die in dem Gebiet wohnen, wo die FTZ-Bestimmungen vorherrschend sind.

Sollte das Gerät auch für Frequenzen ausserhalb des in den FTZ-Bestimmungen angegebenen Bereiches empfangsbereit sein, bitten wir, den Bereich durch Nachstellen des Kernes in der Oszillatortspule (in der Abbildung mit "FTZ" gekennzeichnet) so zu korrigieren, dass er den Bestimmungen entspricht.

2. TEST EQUIPMENT REQUIRED FOR SERVICING

This table lists the test equipment required for servicing the Model SR-6000 Receiver.

Item	Manufacturer and Model No.	Use
AM Signal Generator		Signal source for AM alignment
Test Loop		Use with AM Signal Generator
FM Signal Generator MPX Signal Generator	Sound Technology Model 1000A	Signal source for FM alignment Stereo separation alignment and trouble shooting
Distortion Analyzer Audio Oscillator AC VTVM	Sound Technology Model 1700A	Distortion measurements Sinewave and squarewave signal source Voltage measurements (AC)
Oscilloscope	Tektronix Model T932 Philips Model 3232	Waveform analysis and trouble shooting and ASO alignment
Frequency Counter	Fluke Model 1900A	MPX Oscillator adjustment (VCO)
Circuit Tester		Trouble shooting
DC VTVM	Fluke Model 8000 "Digital" Simpson Model 313, Triplet Model 801	Voltage measurements (DC)
AC Wattmeter	Simpson Model 1379	Monitors primary power to amplifier
AC Ammeter	Commercial Grade (1-10A)	Monitors amplifier output under short circuit condition
Line Voltmeter	Simpson Model 1359	Monitors potential of primary power to amplifier
Variable Autotransformer	Superior Electronic Co., Powerstat Model 116B-10A	Adjusts level of primary power to amplifier
Shorting Plug	Use phono plug with 600-ohm across center pin and shell	Shorts amplifier input to eliminate noise pickup
Output Load (8 ohms, ± 0.5%, 100W)	Commercial Grade	Provides 8-ohm load for amplifier output termination
Output Load (4 ohms, ± 0.5%, 100W)	Commercial Grade	Provides 4-ohm load for amplifier output termination

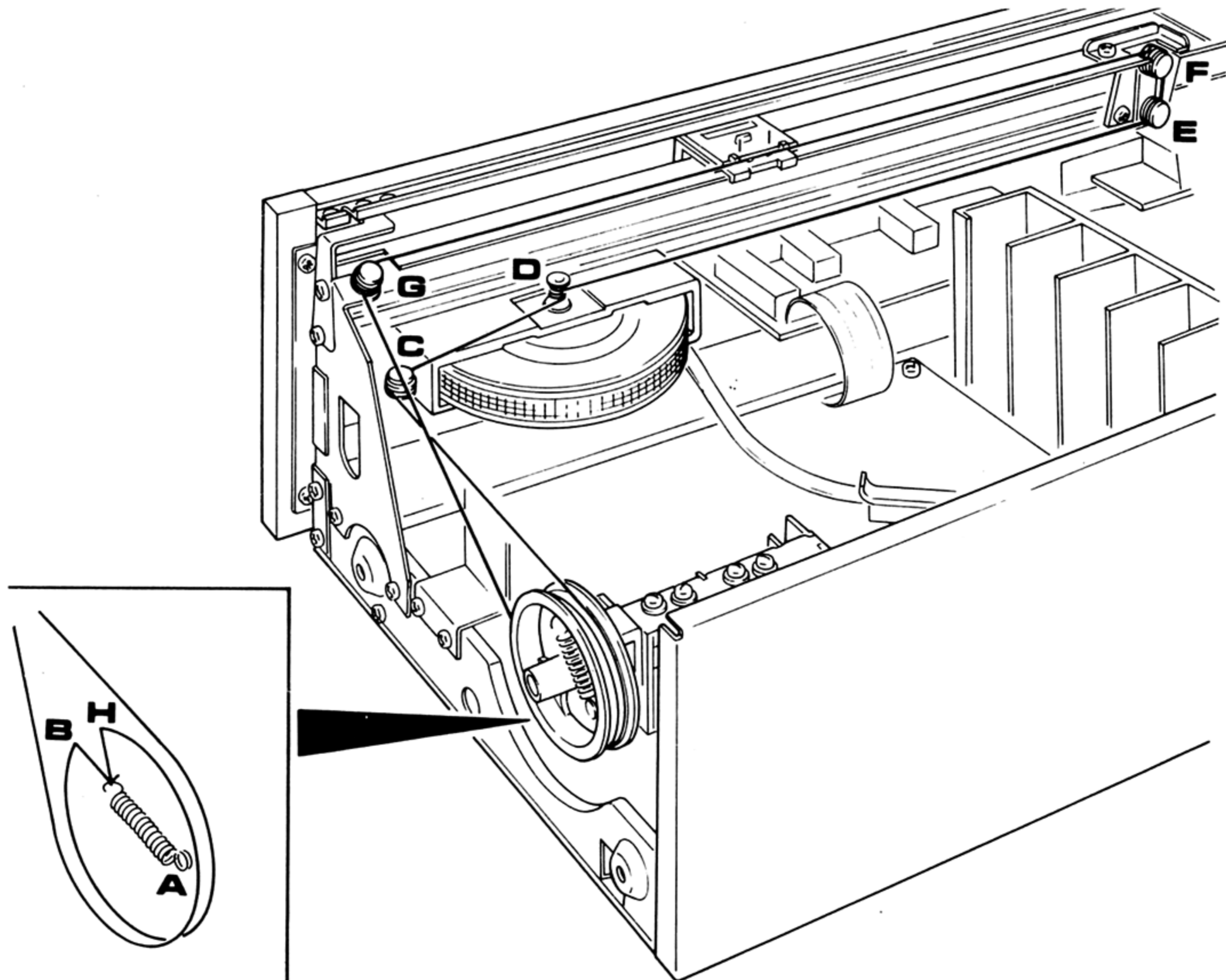

Figure 1. Dial Stringing

3. ALIGNMENT PROCEDURES

* A dummy resistor of 47 kohms must be connected across the tape output terminals before alignment.

3.1 FM ALIGNMENT PROCEDURES

(Selector switch in the "FM" position)

Step	Signal Source Connection	Signal Frequency	Indicator Connection	Set Dial Pointer to:	Adjust:
FM IF ALIGNMENT					
1	Sweep generator to point (B) through 5pF capacitor	10.7 MHz marker at 10.6, 10.7 and 10.8 MHz	Oscilloscope to point (C)	Quiet point on band.	L105 for maximum and symmetric response.
2			Oscilloscope to point (D)		L109 & L110 for straight and symmetric "S" curve response.
3	Repeat steps 1 and 2.				
FM RF ALIGNMENT					
1	RF generator to FM antenna terminals (A) through matching network (300 ohms, balanced) Maintain RF level below limit.)	87.4 MHz	VTVM to L or R channel output (JV11)	87.3 MHz with tuning gang closed.	L106 for maximum output.
2		109 MHz		109 MHz with tuning gang open.	C111 for maximum output.
3		90 MHz		90 MHz	L101, L103 for maximum output.
4		106 MHz		106 MHz	Ant. RF trimmer for maximum output.
5	Repeat steps 1 to 4.				
6	Check overall response curve and repeat above steps as necessary to obtain maximum sensitivity.				
7	No connection	No signal	—	—	L109 core for FM TUNING meter (MX01) pointer indicated its center.
8	RF generator 1 mV output to FM antenna terminals (A) through matching network (300 ohms, balanced)	98 MHz	Distortion meter to L or R channel output (JV11)	98 MHz	L110 core for minimum distortion.
9			—		R134 to R136 so that signal strength meter MX02 may read 80%.
MUTING CIRCUIT ALIGNMENT					
1	RF generator 12.5μV output to FM antenna terminals (A) through matching network (300 ohms, balanced)	98 MHz	VTVM to R or L channel output (JV11)	98 MHz	R131 for 12.5μV threshold level. (During the adjustment turn the FM MUTING push-switch "ON").

3.2 MULTIPLEX ALIGNMENT PROCEDURES

(Selector switch in the "FM" position)

Step	Signal Source Connection	Signal Frequency	Indicator Connection	Set Dial Pointer to:	Adjust:
1	RF generator to FM antenna terminals (A) through matching network (300 ohms, balanced), with 1mV FM stereo simulator RF level and 100% modulation (pilot 9%)	No modulation	Frequency counter to point (D) (J302)	98 MHz	R302 so that frequency counter may precisely read 76 kHz.
2		Stereo, left (1,000 Hz)	VTVM to right channel (JV11)		R326 for maximum output and same separation in both channels.
3		Stereo, right (1,000 Hz)	VTVM to left channel output terminal (JV11)		
4	Repeat steps 2 and 3.				
5	RF generator to FM antenna terminals A through matching network (300 ohms, balanced), with 1mV FM stereo simulator RF level and 100% modulation (pilot 9%)	Pilot only	VTVM to right channel output (JV11)	98 MHz	R306 so that minimum output should be the same in both channels.

3.3 AM ALIGNMENT PROCEDURES

(Selector switch in the "AM" position)

Step	Signal Source Connection	Signal Frequency	Indicator Connection	Set Dial Pointer to:	Adjust:
AM IF ALIGNMENT					
1	Sweep generator to point (E)	450 kHz marker	Oscilloscope to point (F) (JA03)	Quiet point on band.	LA02 & LA03 for maximum and symmetric response.
AM RF ALIGNMENT					
1	RF generator to AM antenna terminals through IHF dummy	525 kHz	VTVM to L or R channel output (JV11)	525 kHz with tuning gang closed.	LA01 for maximum output.
2		1,630 kHz		1,630 kHz with tuning gang open.	OSC. trimmer for maximum output.
3		600 kHz		600 kHz	L051 for maximum output.
4		1,400 kHz		1,400 kHz	Ant. trimmer for maximum output.
5	Repeat steps 1 to 4 as necessary to obtain maximum sensitivity.				

3.4 AUDIO ALIGNMENT PROCEDURES

(Selector switch in the "AUX" position)

Step	Signal Source Connection	Signal Frequency	Indicator Connection	Adjustment
1	—	—	DC voltmeter in 100 mV or 50 mV range to speaker terminals.	Set RG01 to minimum position. Adjust RN09 (L-ch) and RN10 (R-ch) so that voltmeter reading is ± 3 mV or less.
2	AF oscillator to AUX jack	1 kHz	DC voltmeter in 3 V range to JK07 \oplus and JK03 \ominus (L-ch), or JK08 \oplus and JK03 \ominus (R-ch). AC voltmeter in 30 V range to speaker terminals.	Connect 8 Ω load to speaker terminals. Adjust input signal so that output voltage at speaker terminal is 23.7 V. Adjust RK01 (L-ch) or RK02 (R-ch) so that voltage at JK07, or JK08 is 2.25 V. Check to ensure that LED reading is 70 W.

4. VOLTAGE CONVERSION

To convert the unit to a different power source voltage, change the position as illustrated in the drawing below.

CAUTION: DISCONNECT POWER SUPPLY CORD FROM AC OUTLET BEFORE CONVERTING VOLTAGE. DO NOT DISASSEMBLE THE VOLTAGE SELECTOR ABSOLUTELY.

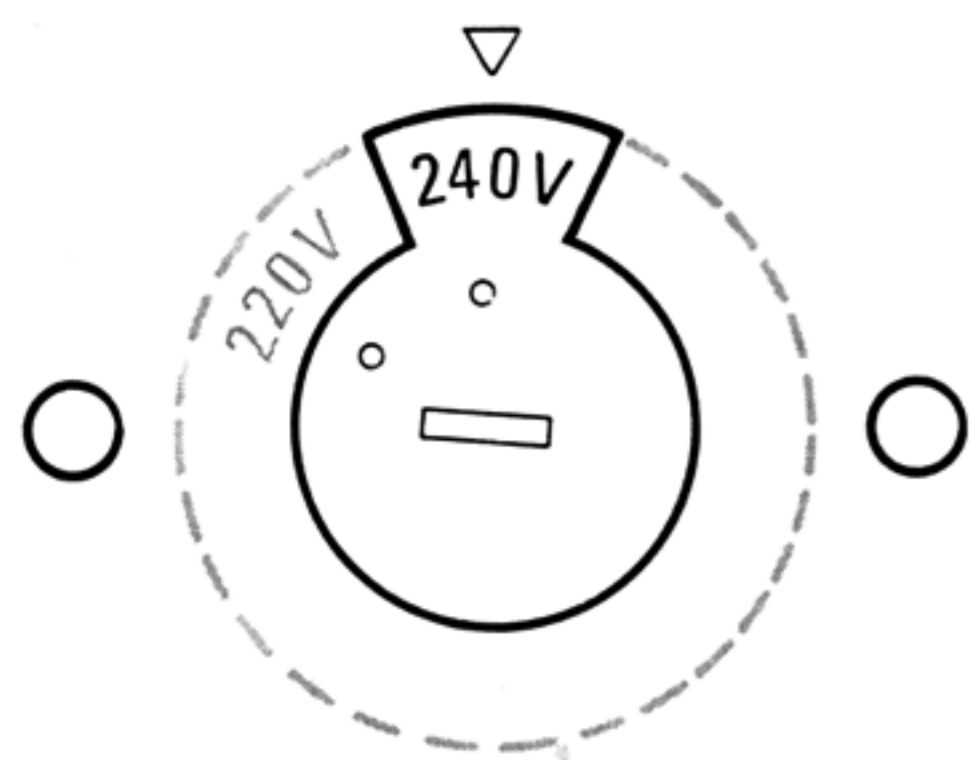
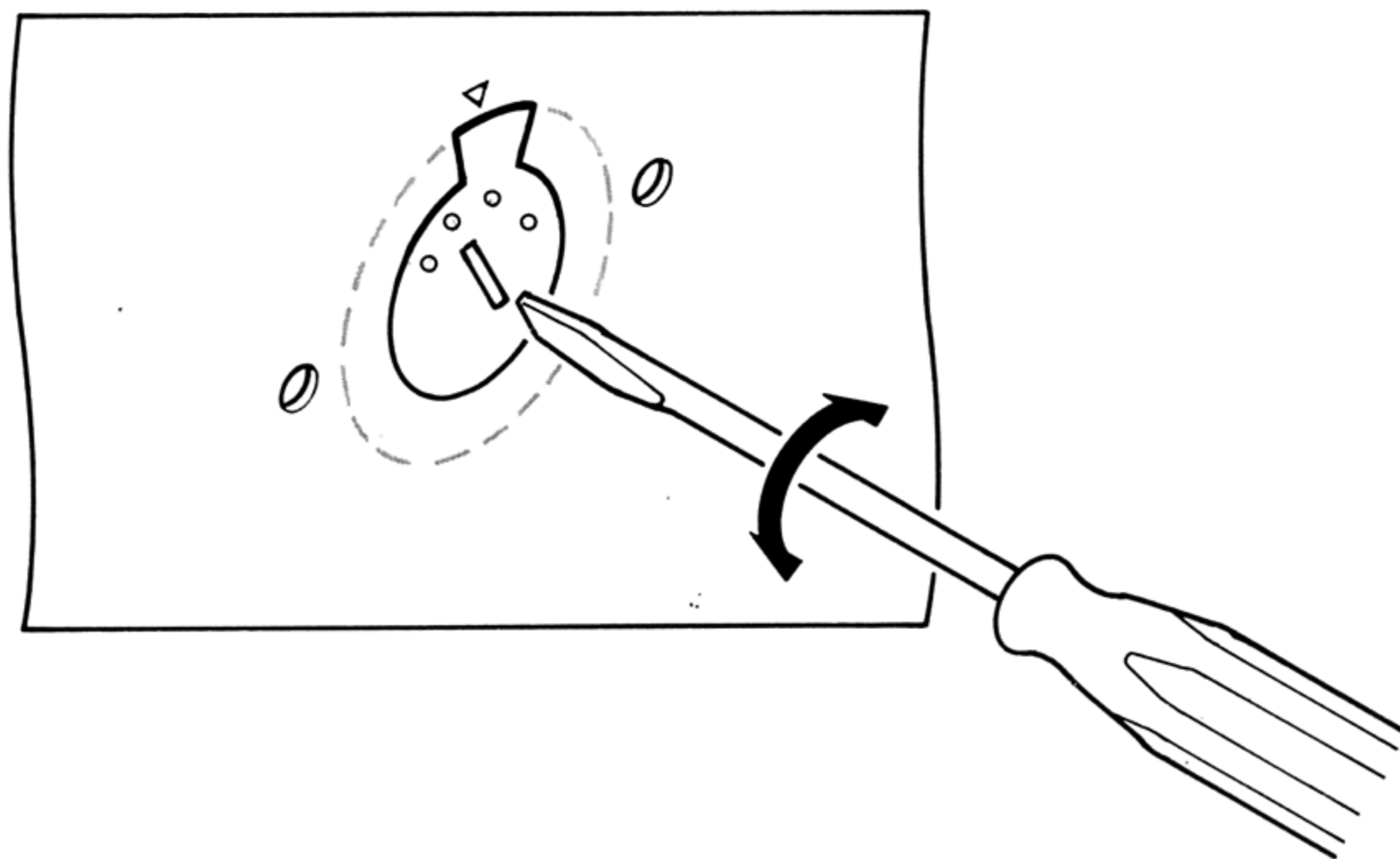

(T) (A) Versions

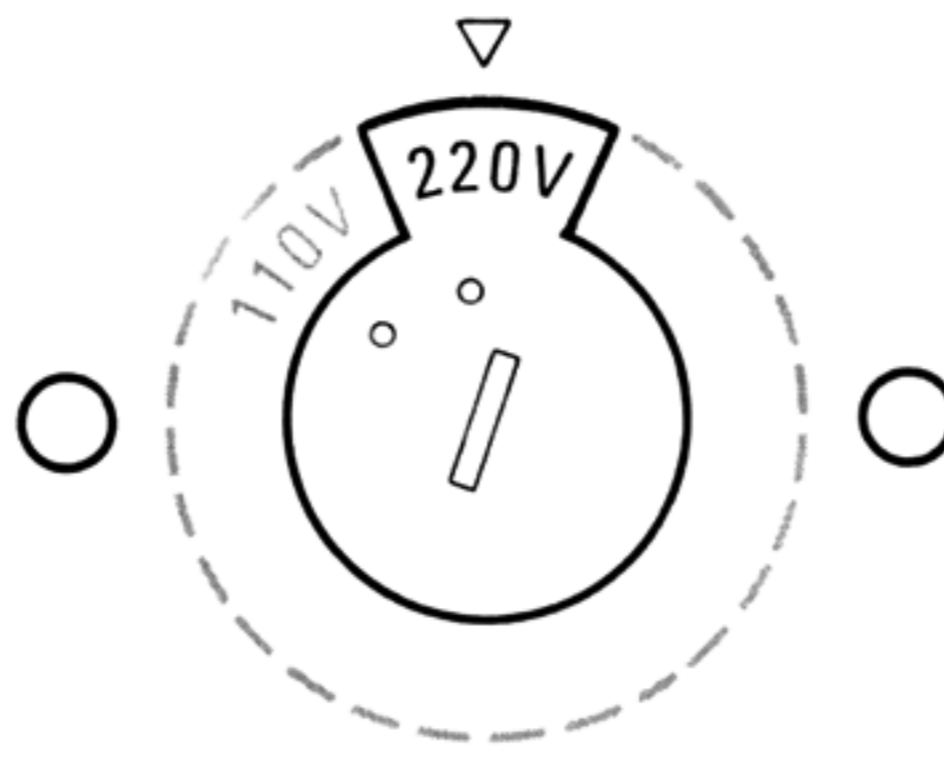

(N) Version

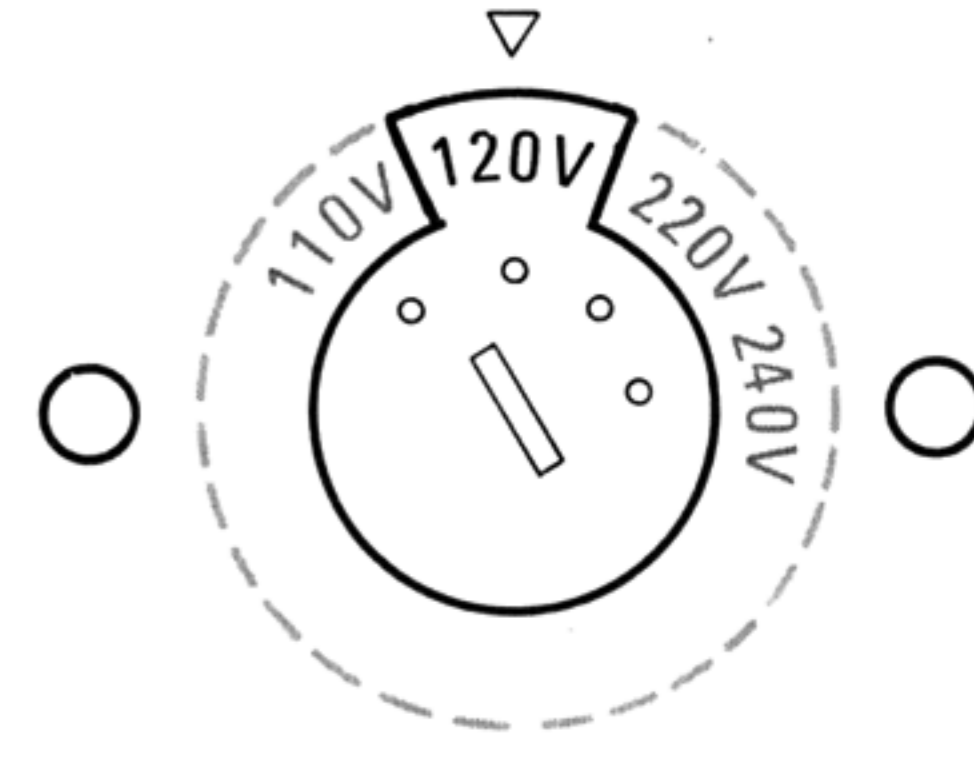

(P) Version

Figure 3. Voltage Conversion

5. DIAGRAMS
5.1 BLOCK DIAGRAM

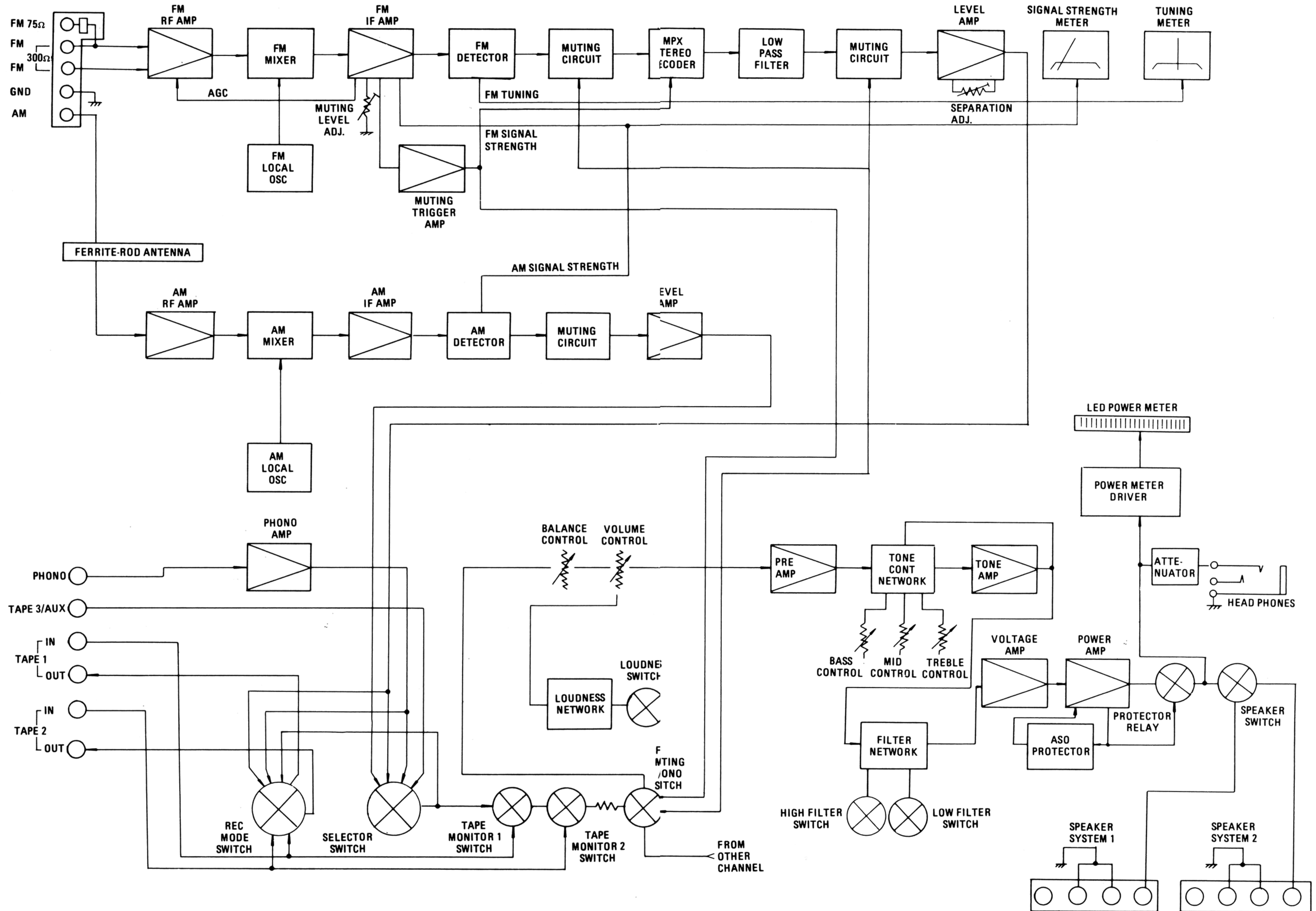

5.2 TUNER/PHONO BOARD SCHEMATIC DIAGRAM AND COMPONENT LOCATIONS - P100 (YK21161710)

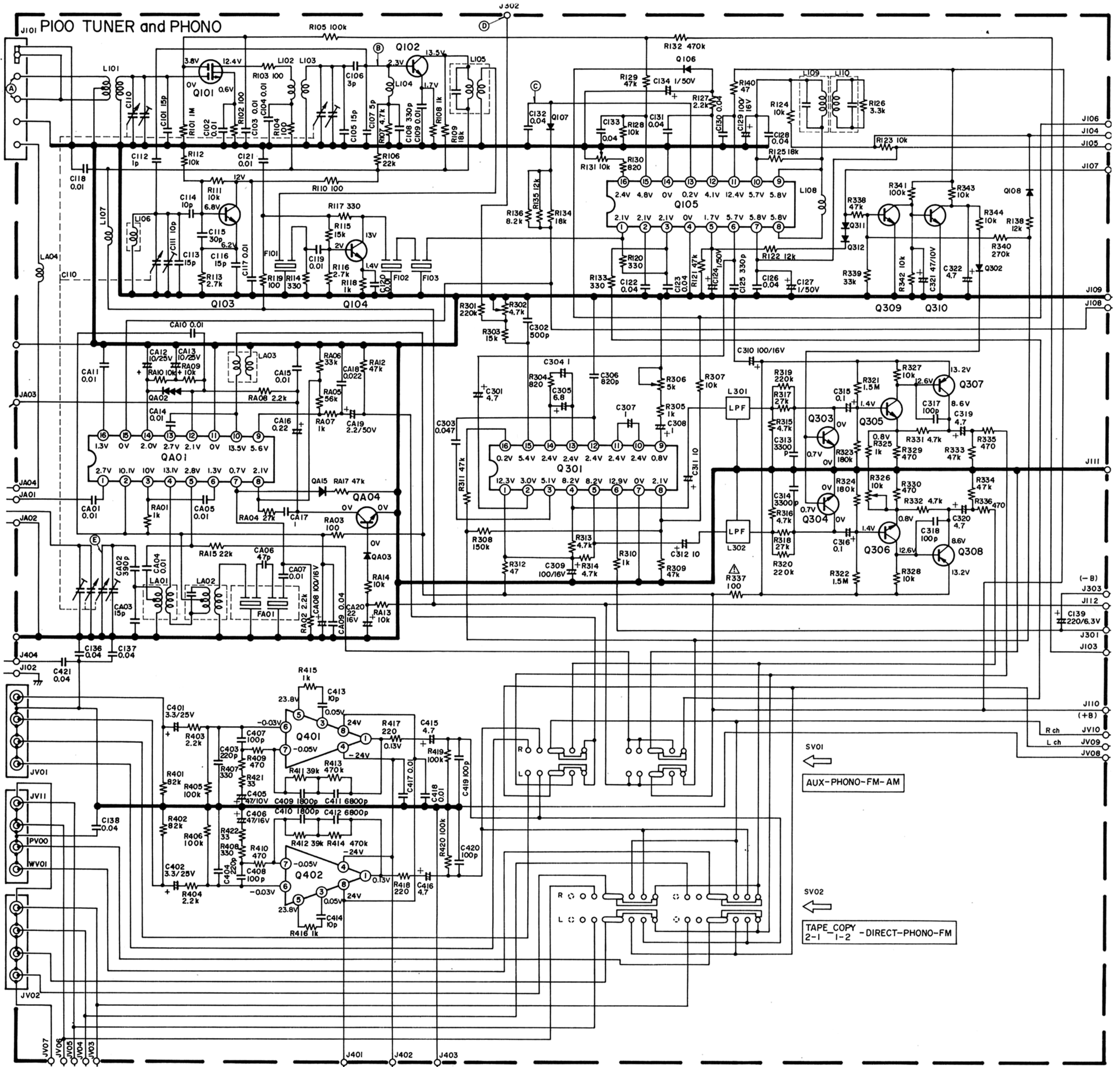

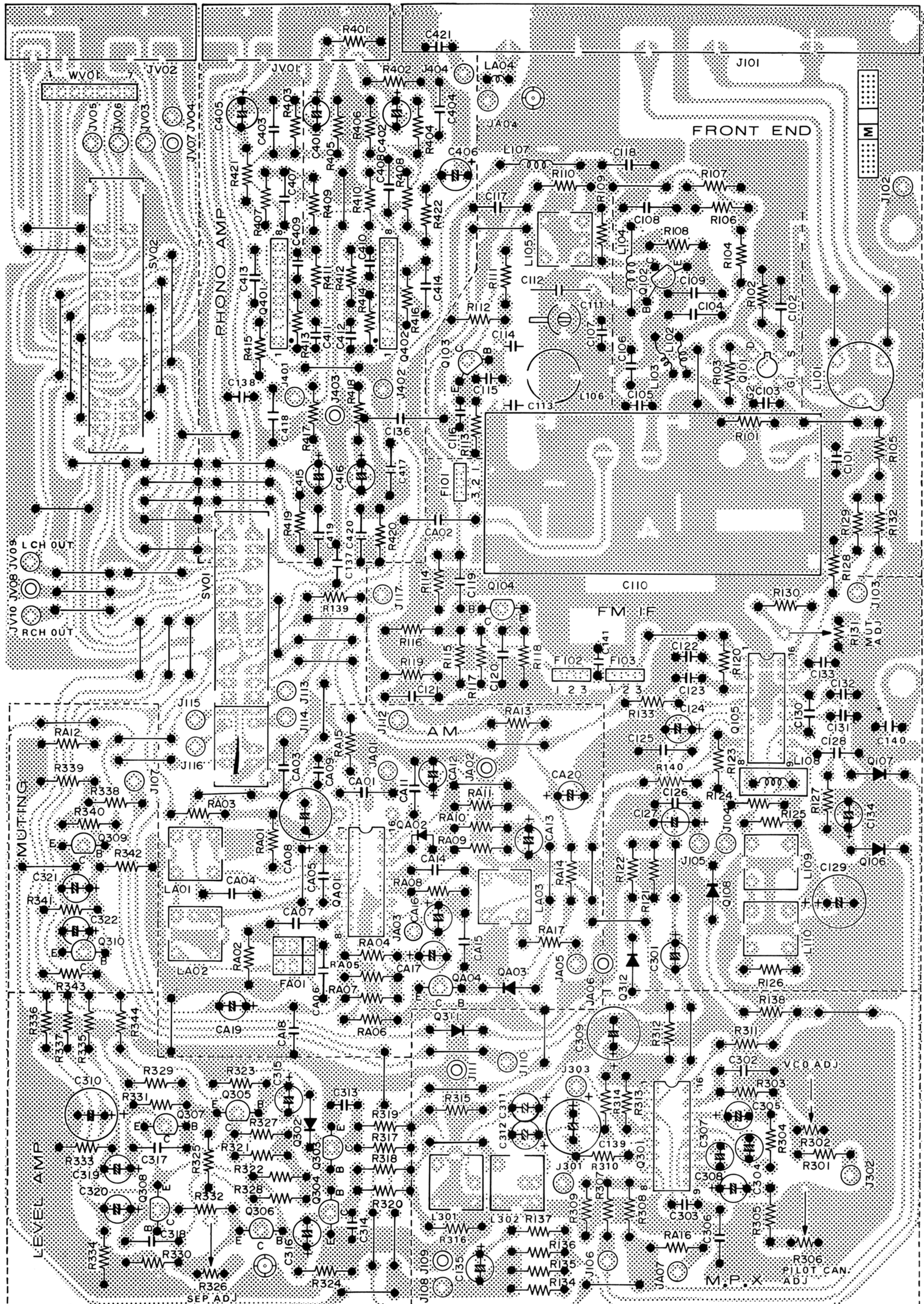

5.3 POWER AMP BOARD SCHEMATIC DIAGRAM AND COMPONENT LOCATIONS - P700

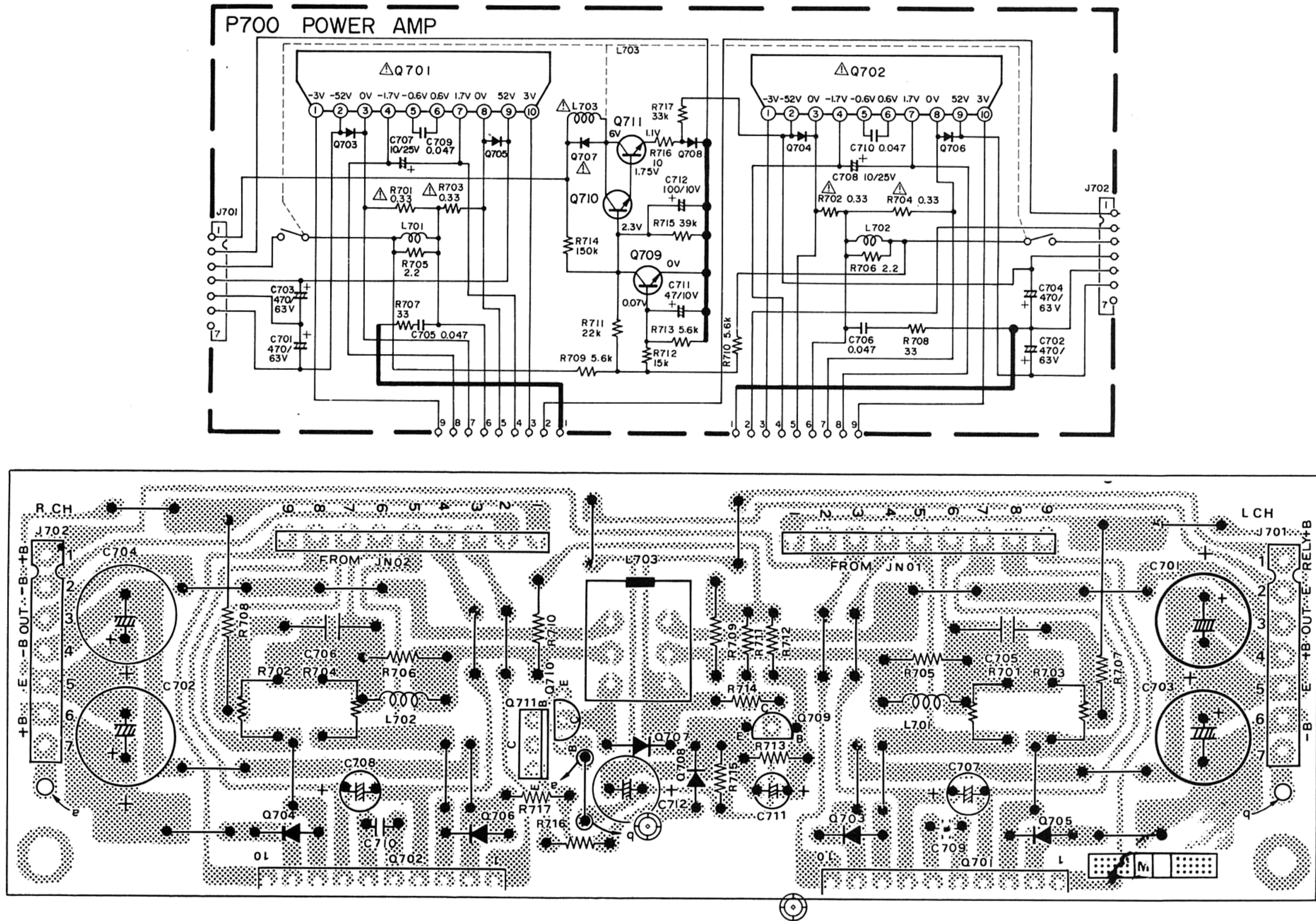

5.4 POWER SUPPLY BOARD SCHEMATIC DIAGRAM AND COMPONENT LOCATIONS - P800

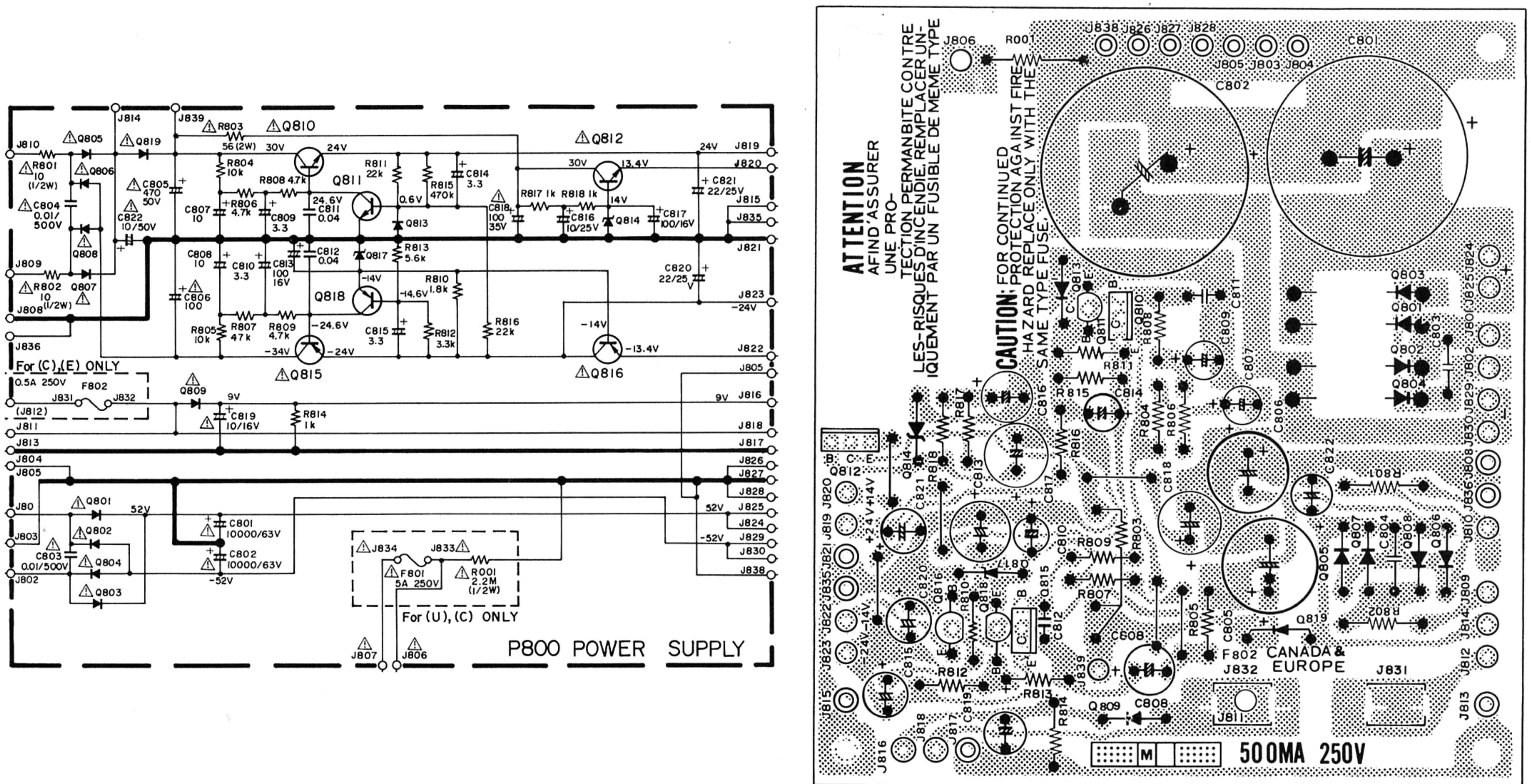

5.5 TONE AMP BOARD SCHEMATIC DIAGRAM AND COMPONENT LOCATIONS - PE00

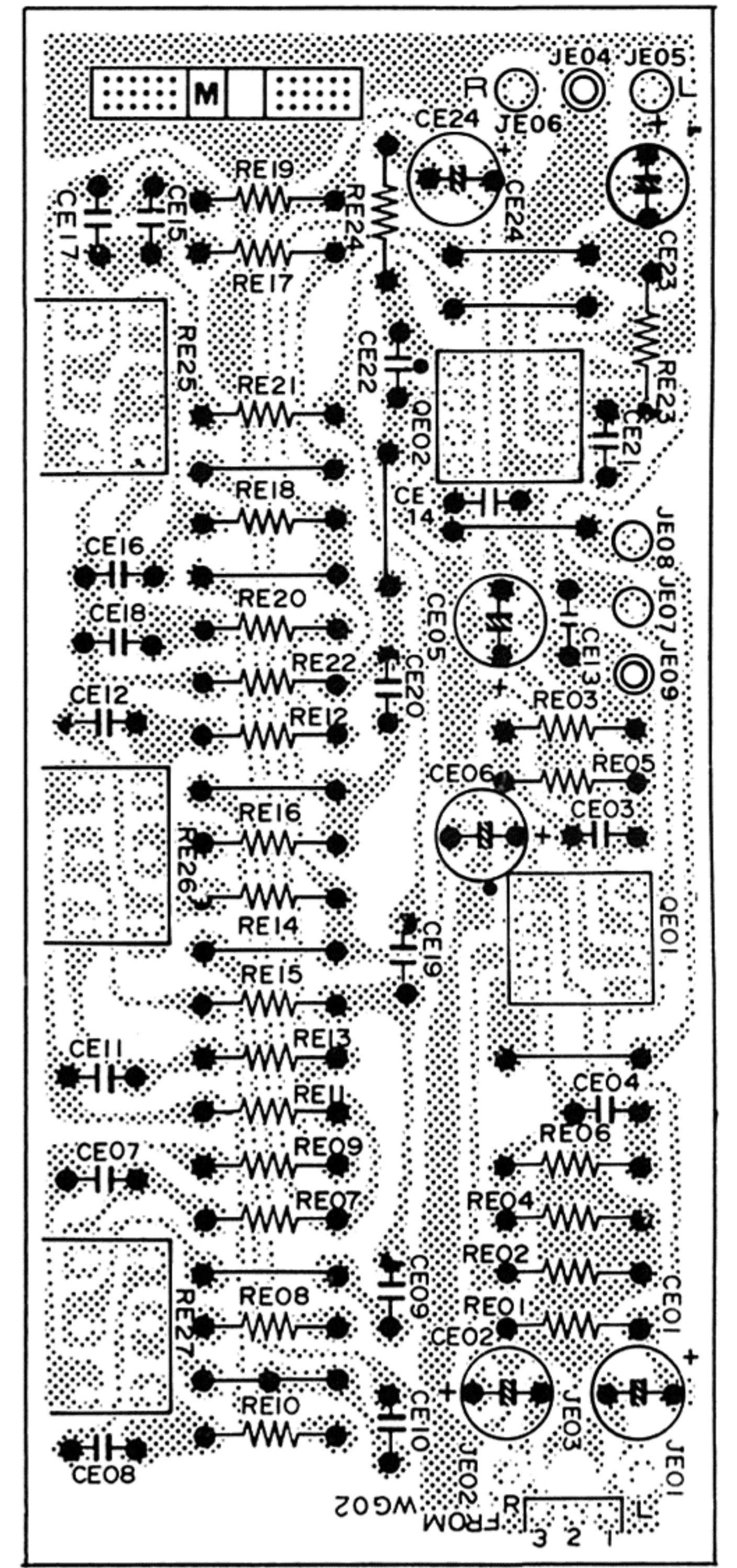
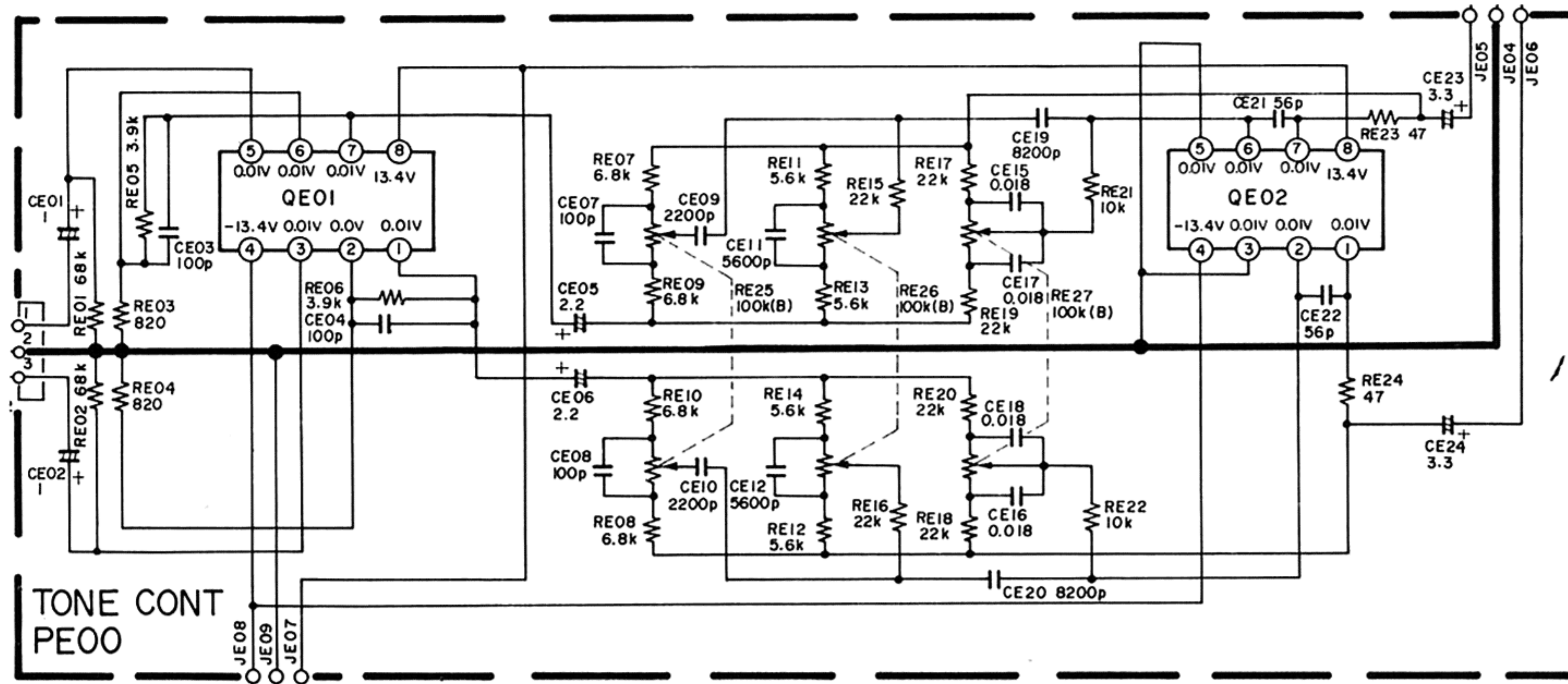

5.6 VOLUME BOARD SCHEMATIC DIAGRAM AND COMPONENT LOCATIONS - PG00

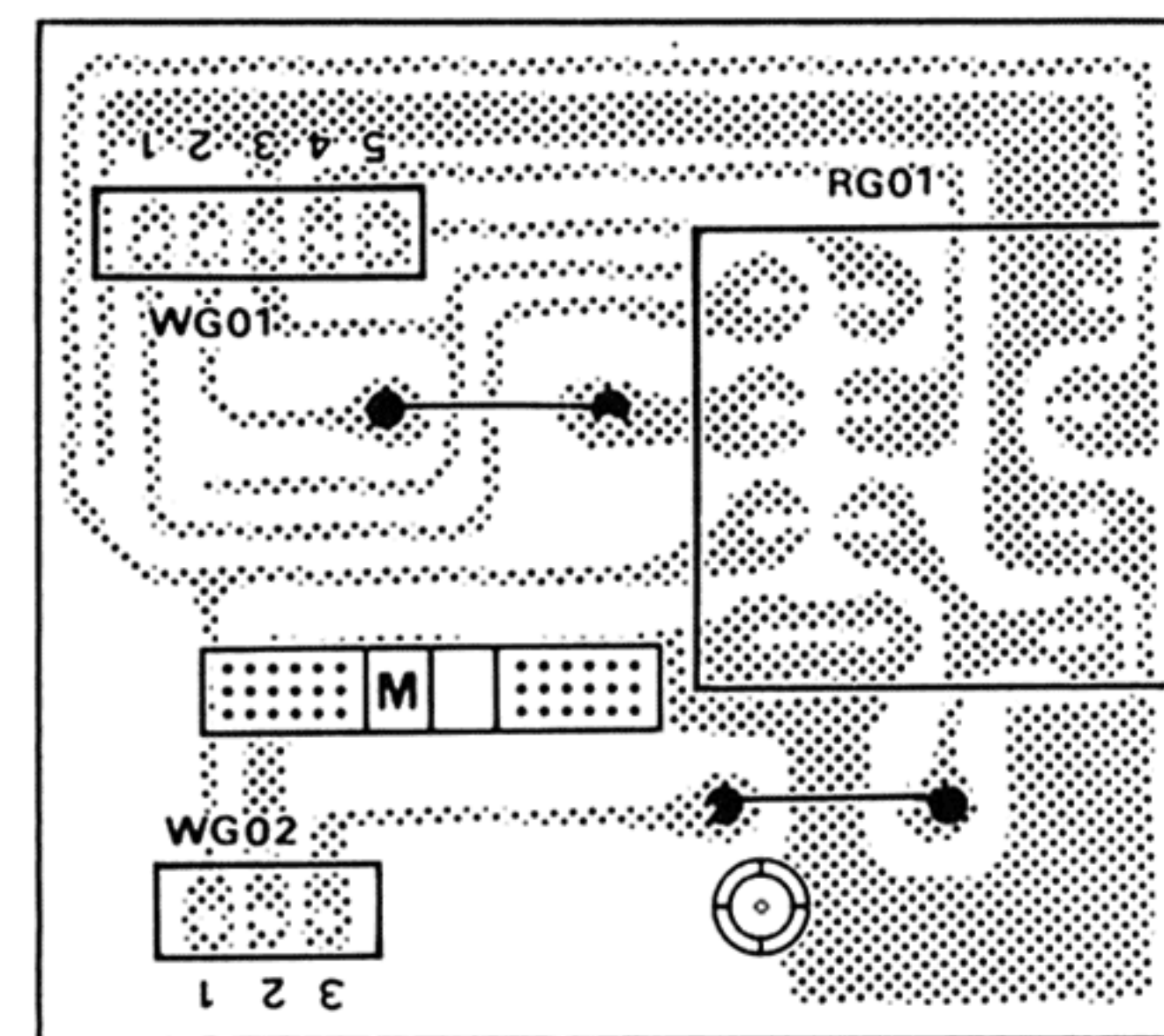
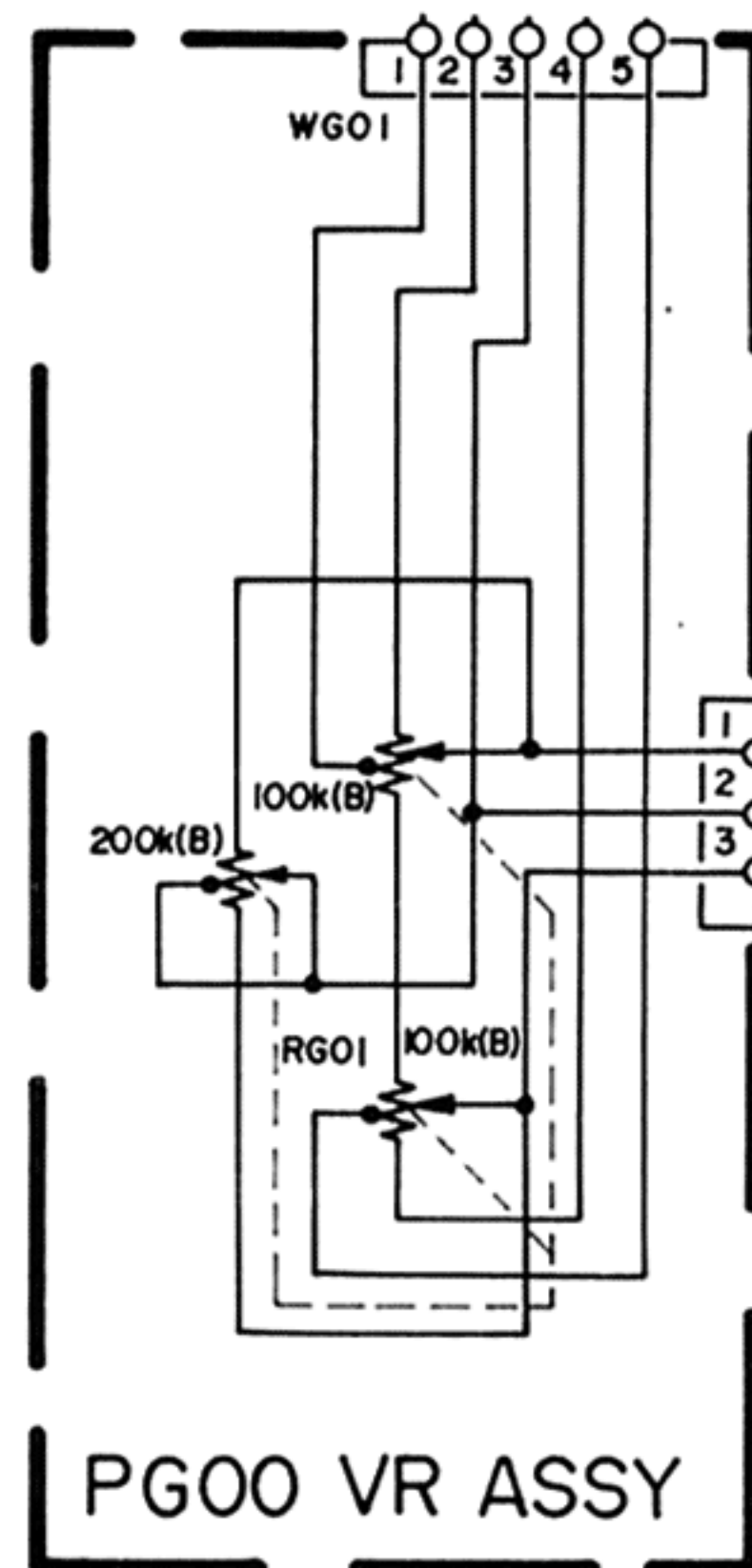

5.7 POWER LED METER AMP BOARD SCHEMATIC DIAGRAM AND COMPONENT LOCATIONS - PK02

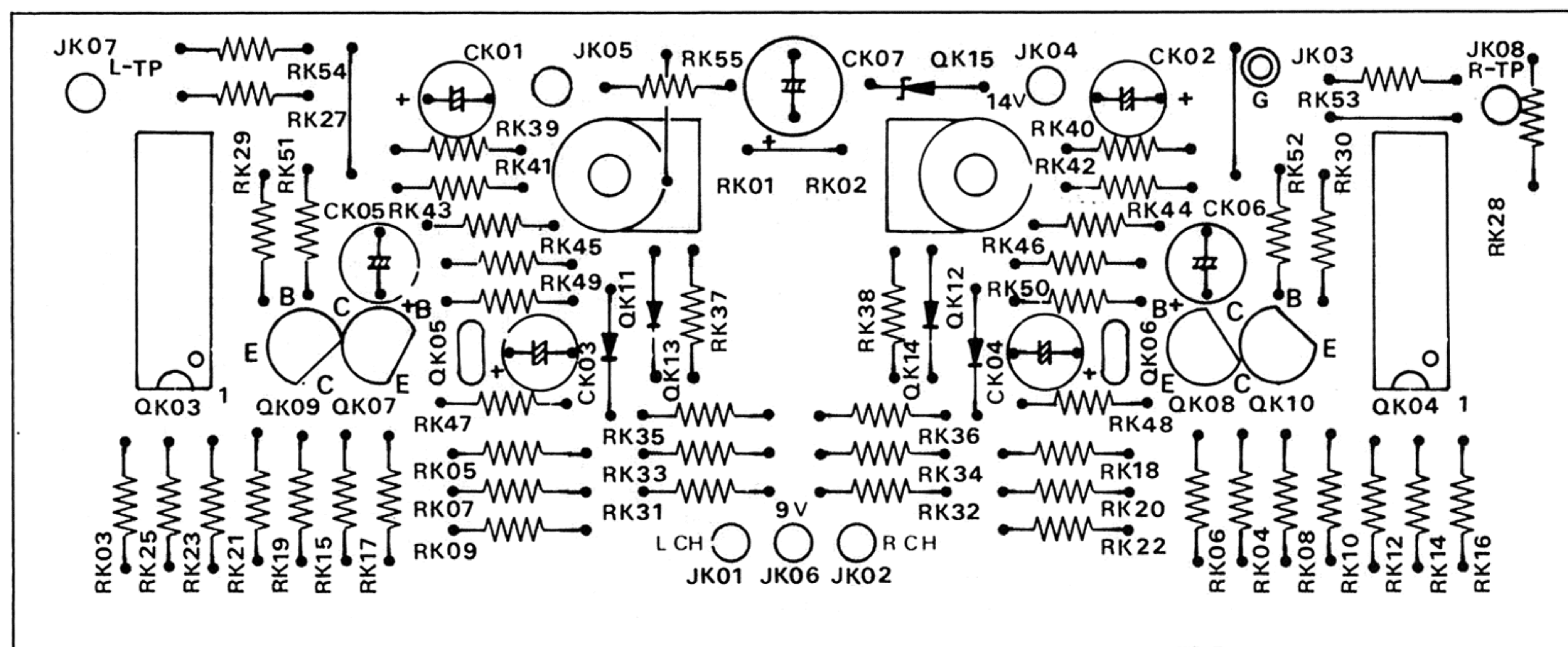
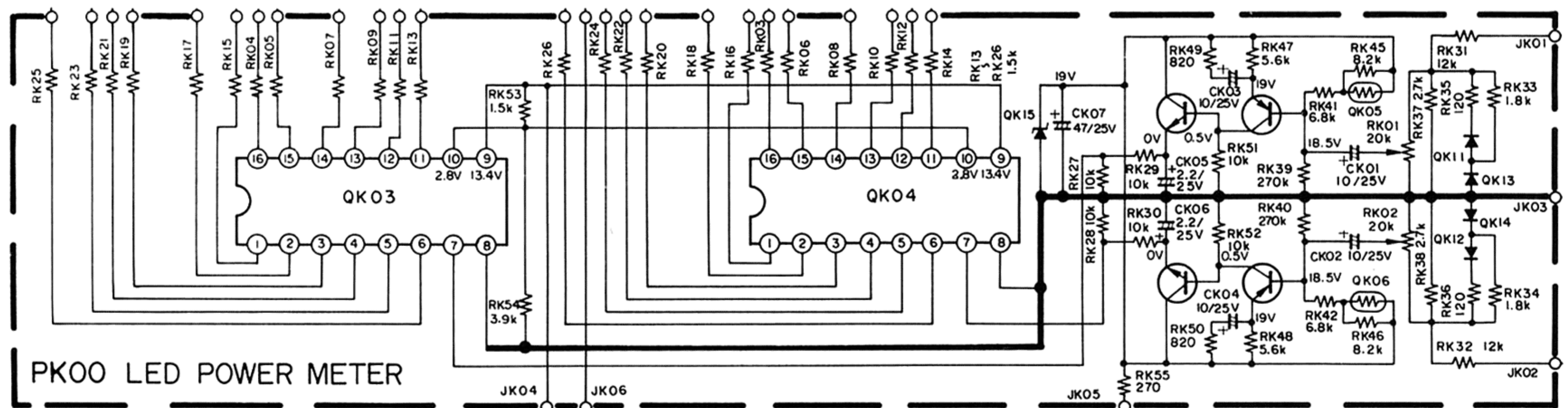

5.8 POWER LED METER BOARD SCHEMATIC DIAGRAM AND COMPONENT LOCATIONS - PK01

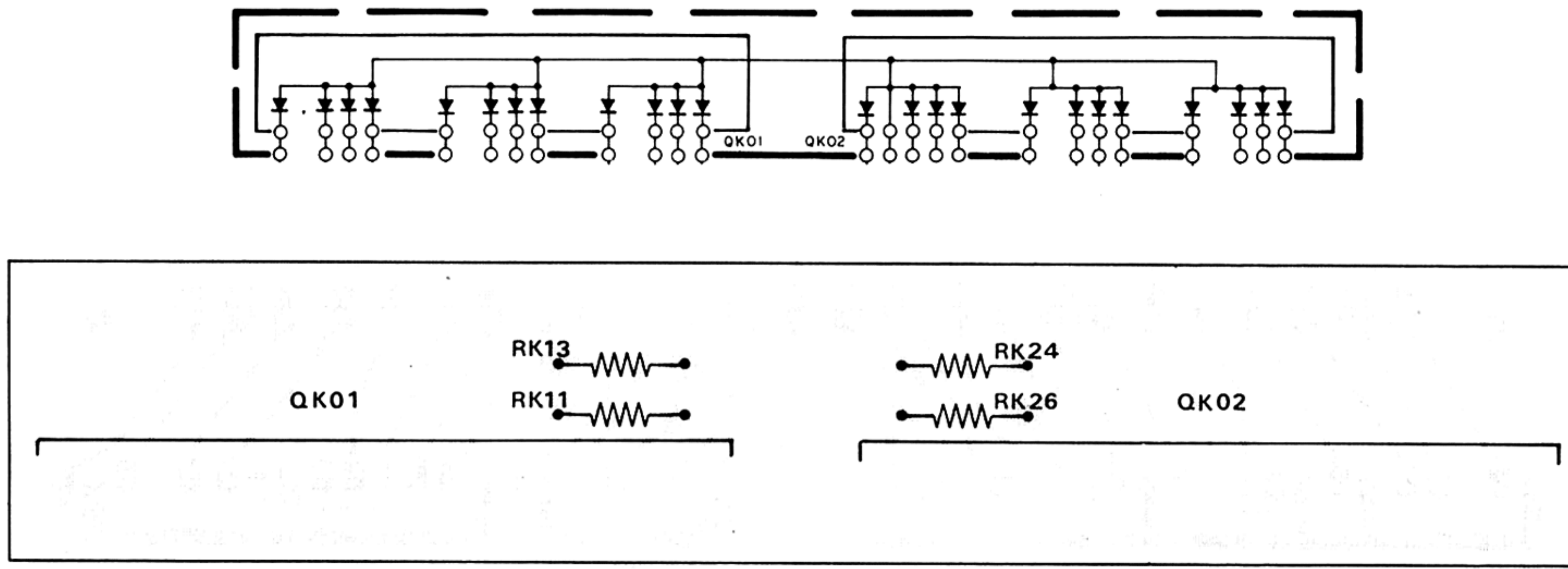

5.9 VOLTAGE AMP BOARD SCHEMATIC DIAGRAM AND COMPONENT LOCATIONS - PN00

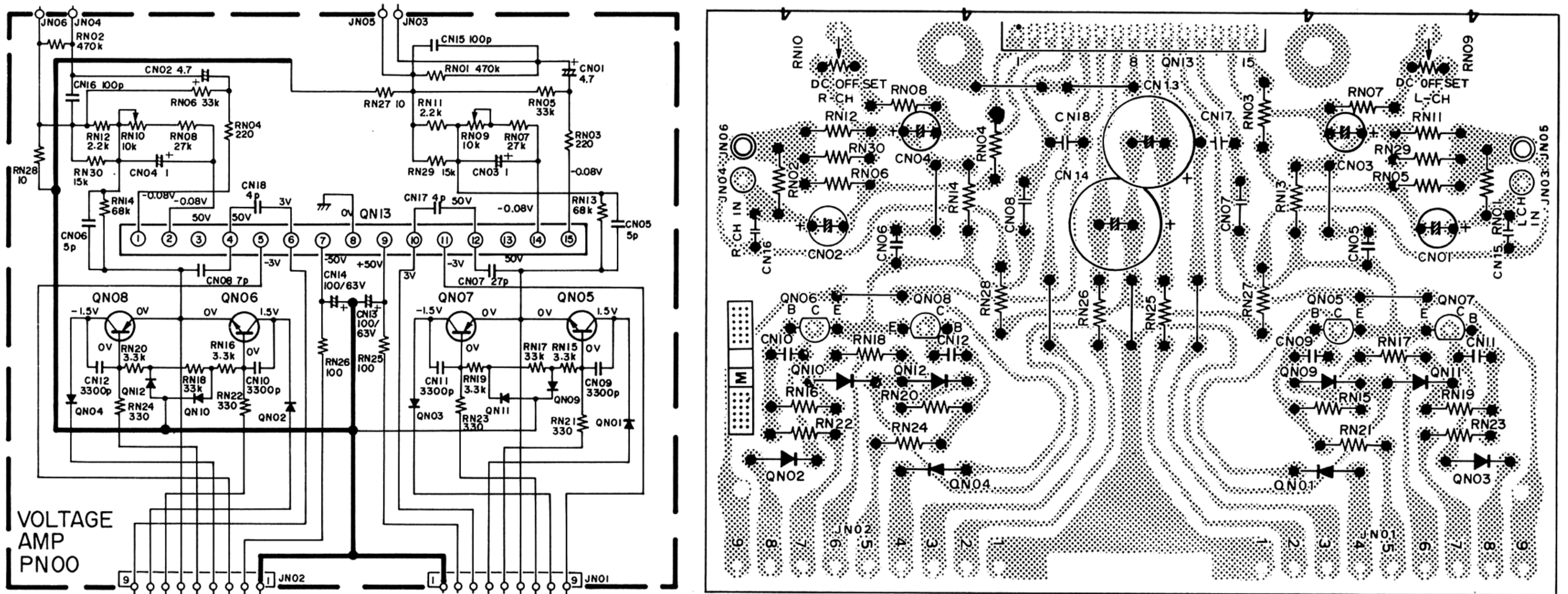

5.10 SWITCH BOARD SCHEMATIC DIAGRAM AND COMPONENT LOCATIONS - PS00

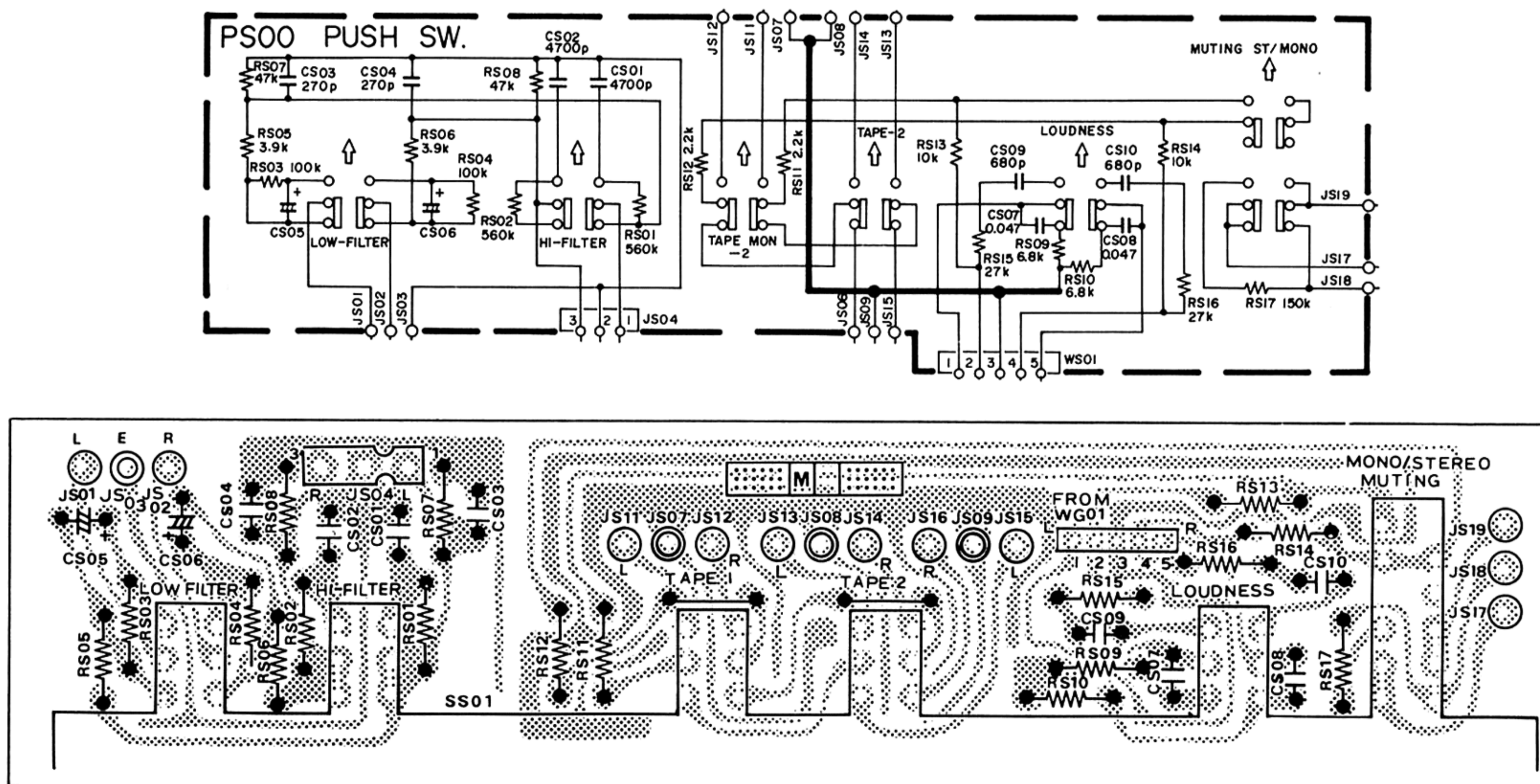

5.11 SPEAKER SWITCH BOARD SCHEMATIC DIAGRAM AND COMPONENT LOCATIONS - PT00

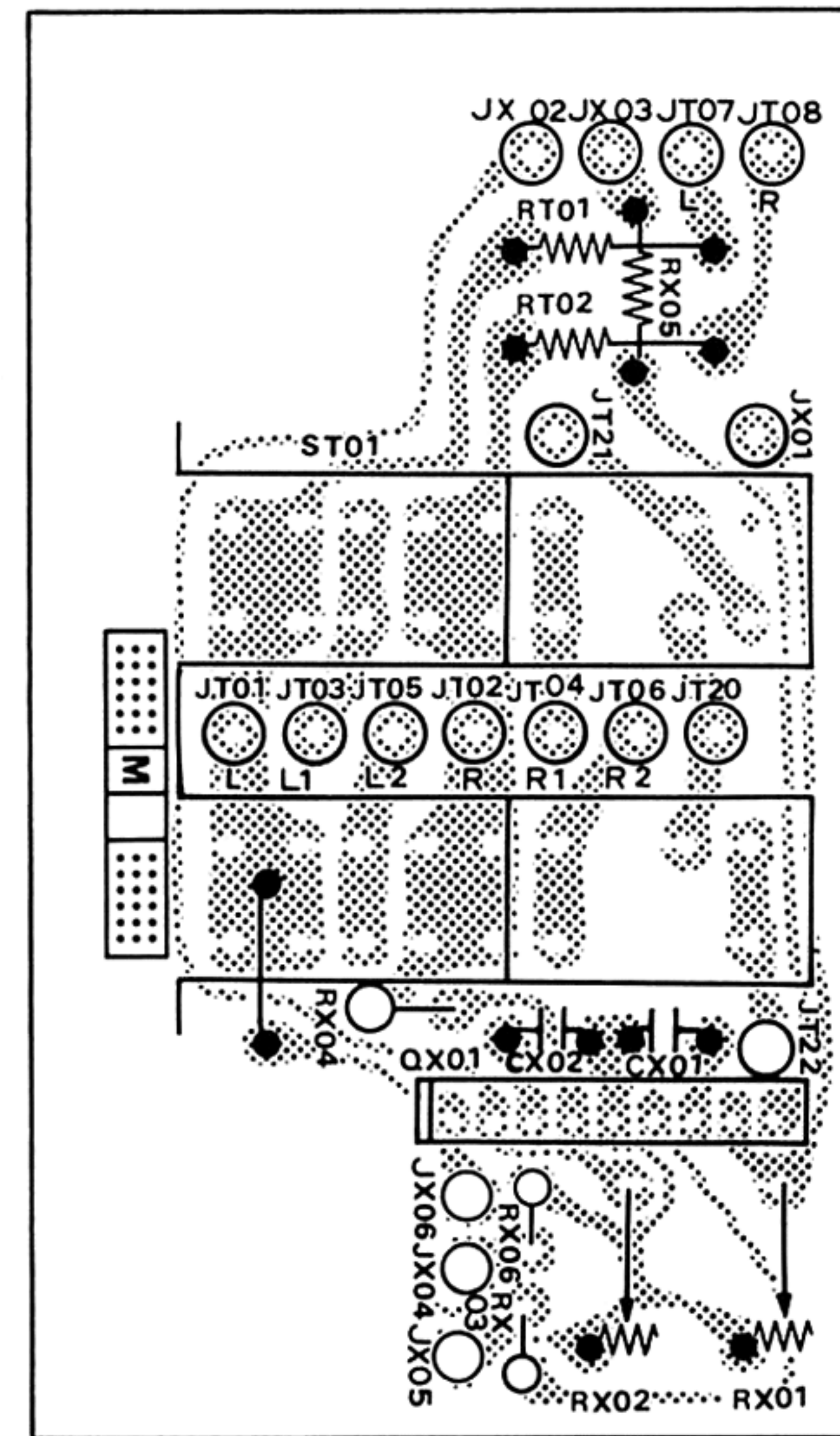
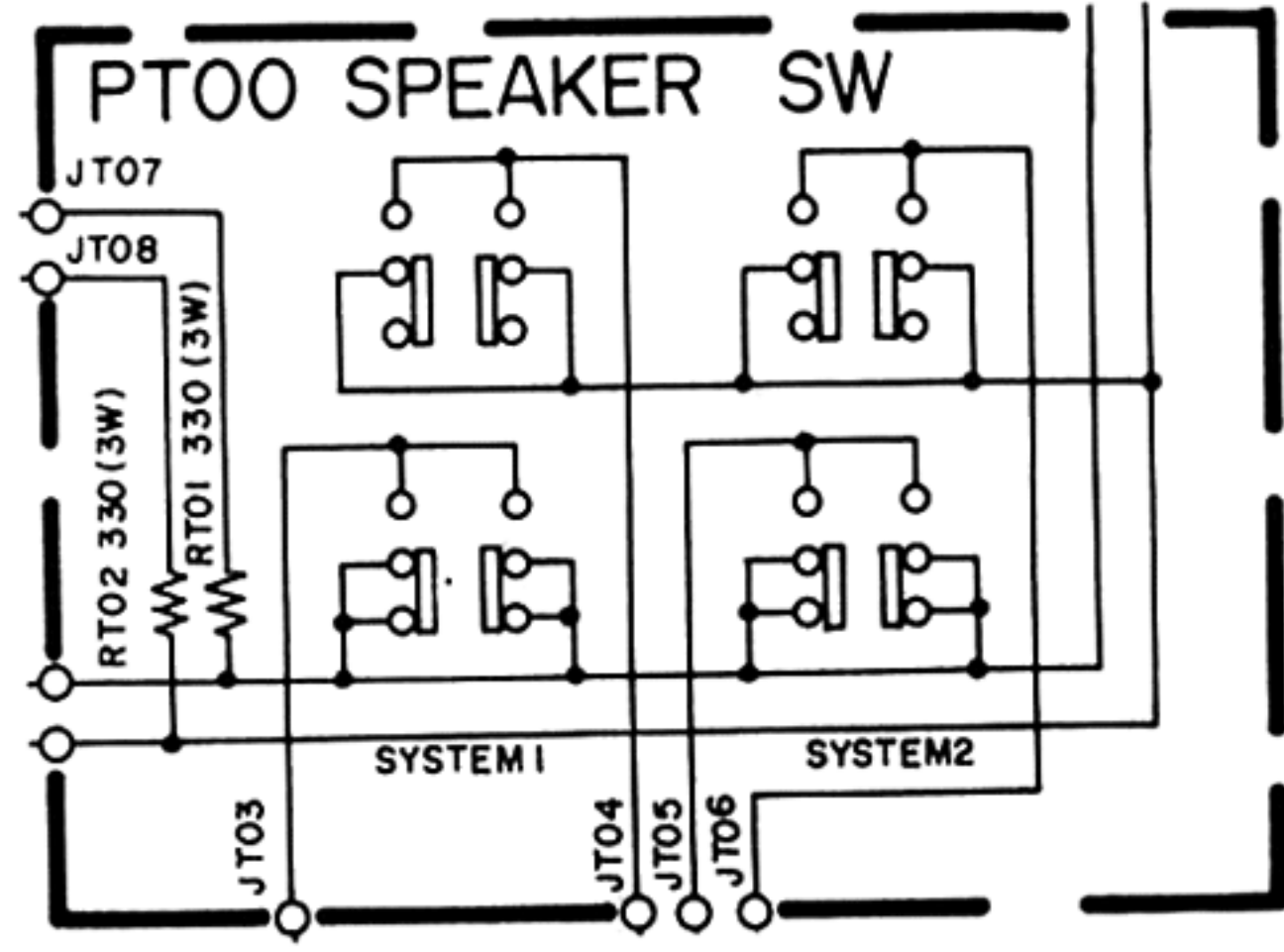

5.12 TAPE INPUT BOARD COMPONENT LOCATIONS - PV00

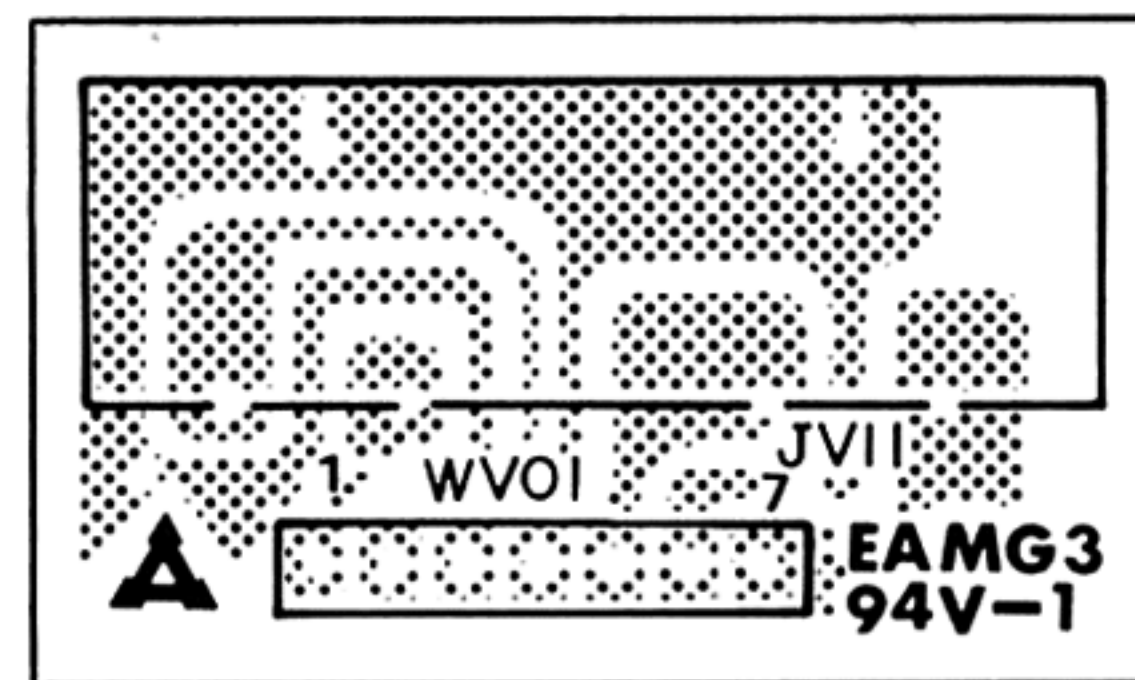

5.13 HEADPHONE BOARD SCHEMATIC DIAGRAM AND COMPONENT LOCATIONS - PW00

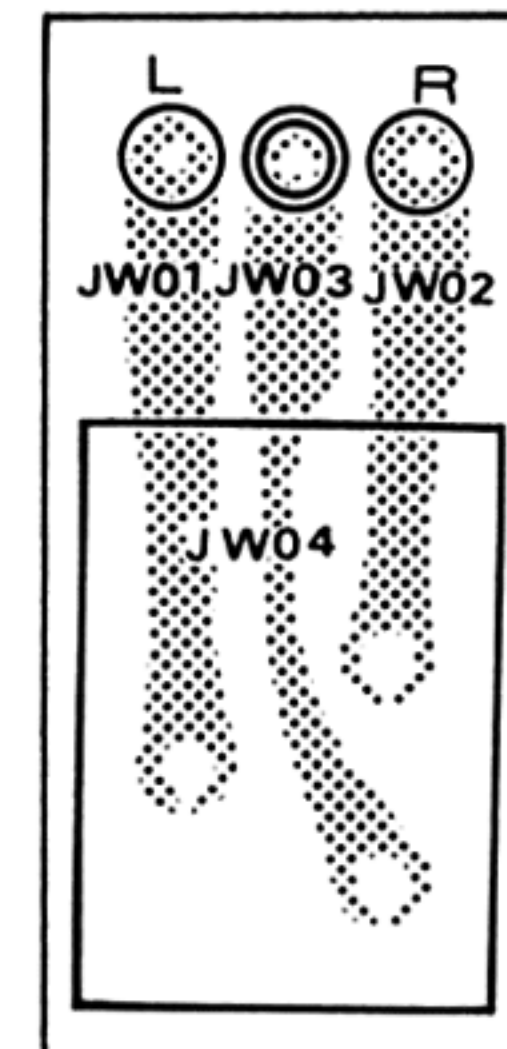
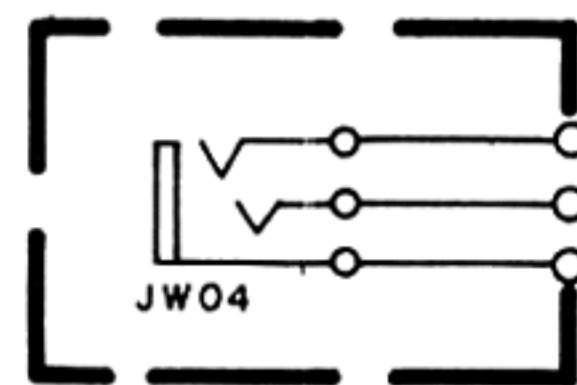

5.14 METER BOARD SCHEMATIC DIAGRAM AND COMPONENT LOCATIONS - PX00

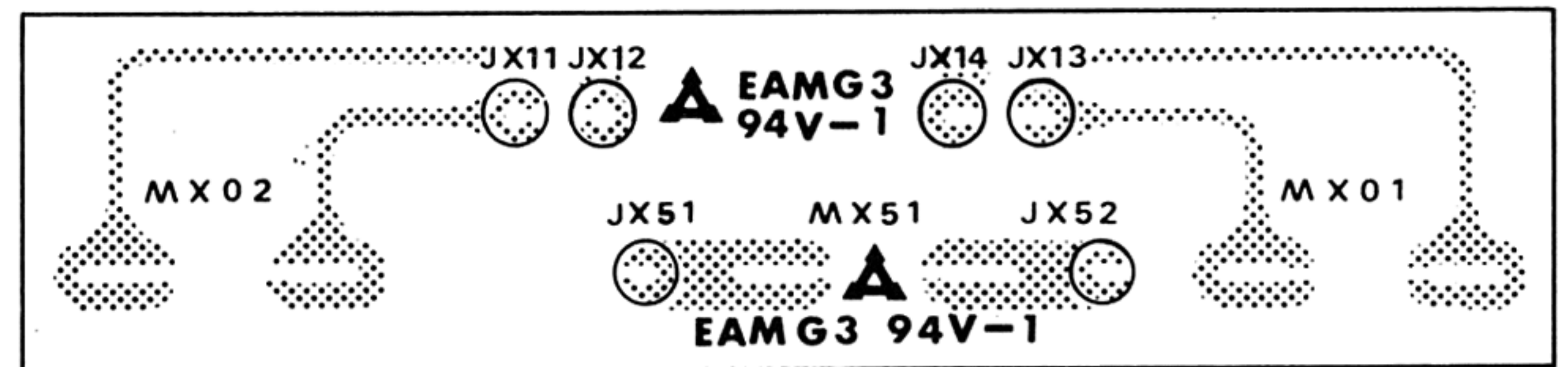
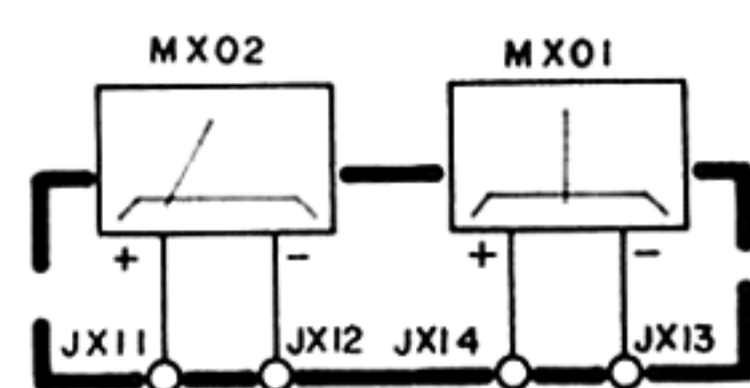

5.15 STEREO LED BOARD SCHEMATIC DIAGRAM AND COMPONENT LOCATIONS - PY00

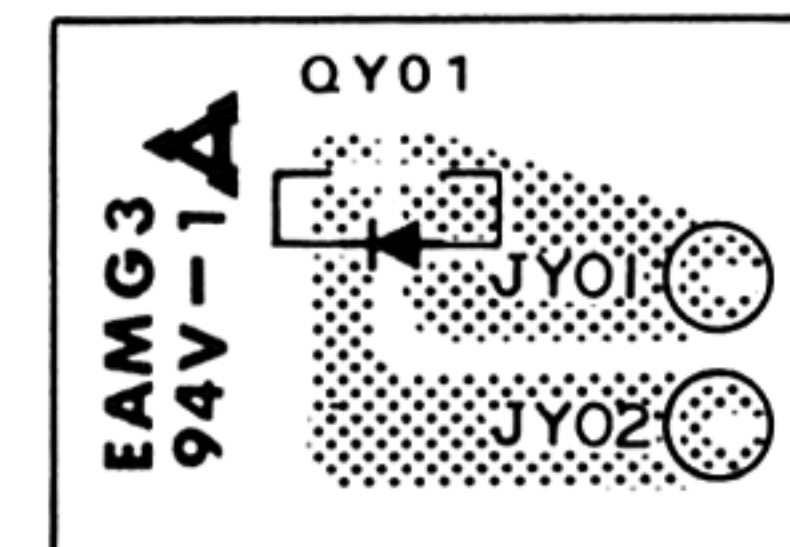
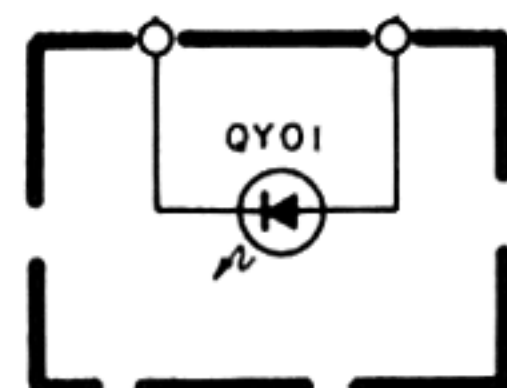

5.16 DIAL POINTER LAMP BOARD SCHEMATIC DIAGRAM AND COMPONENT LOCATIONS - PZ00

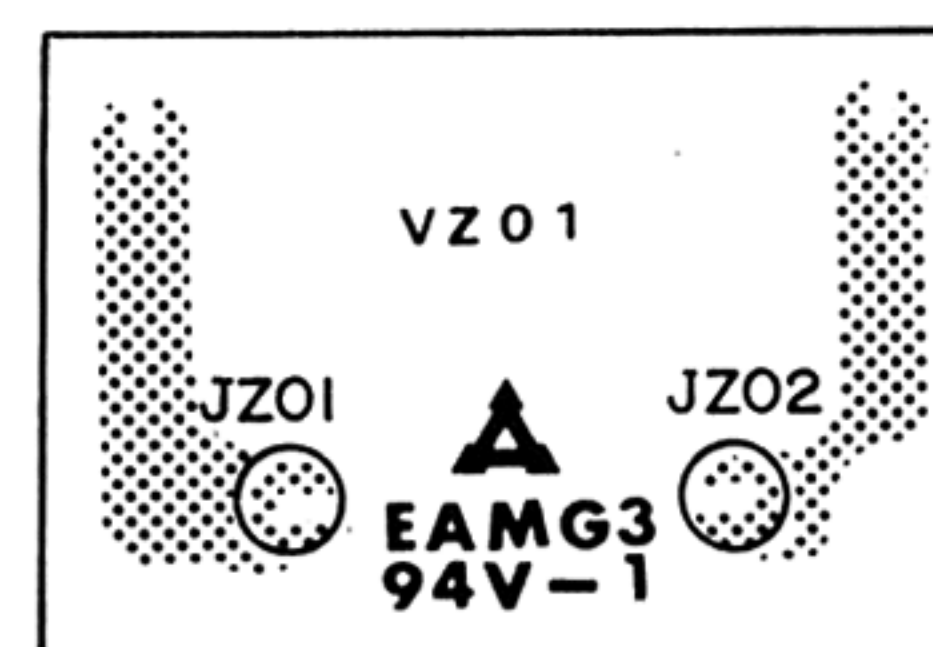
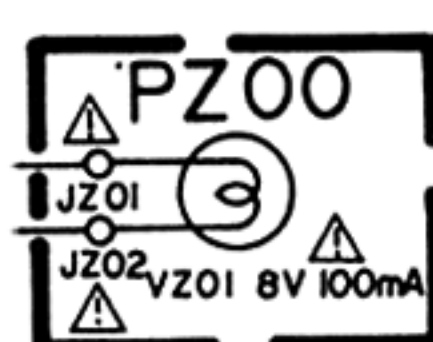

6. EXPLODED VIEWS AND PARTS LIST

6.1 [C01-99] FRONT PANEL

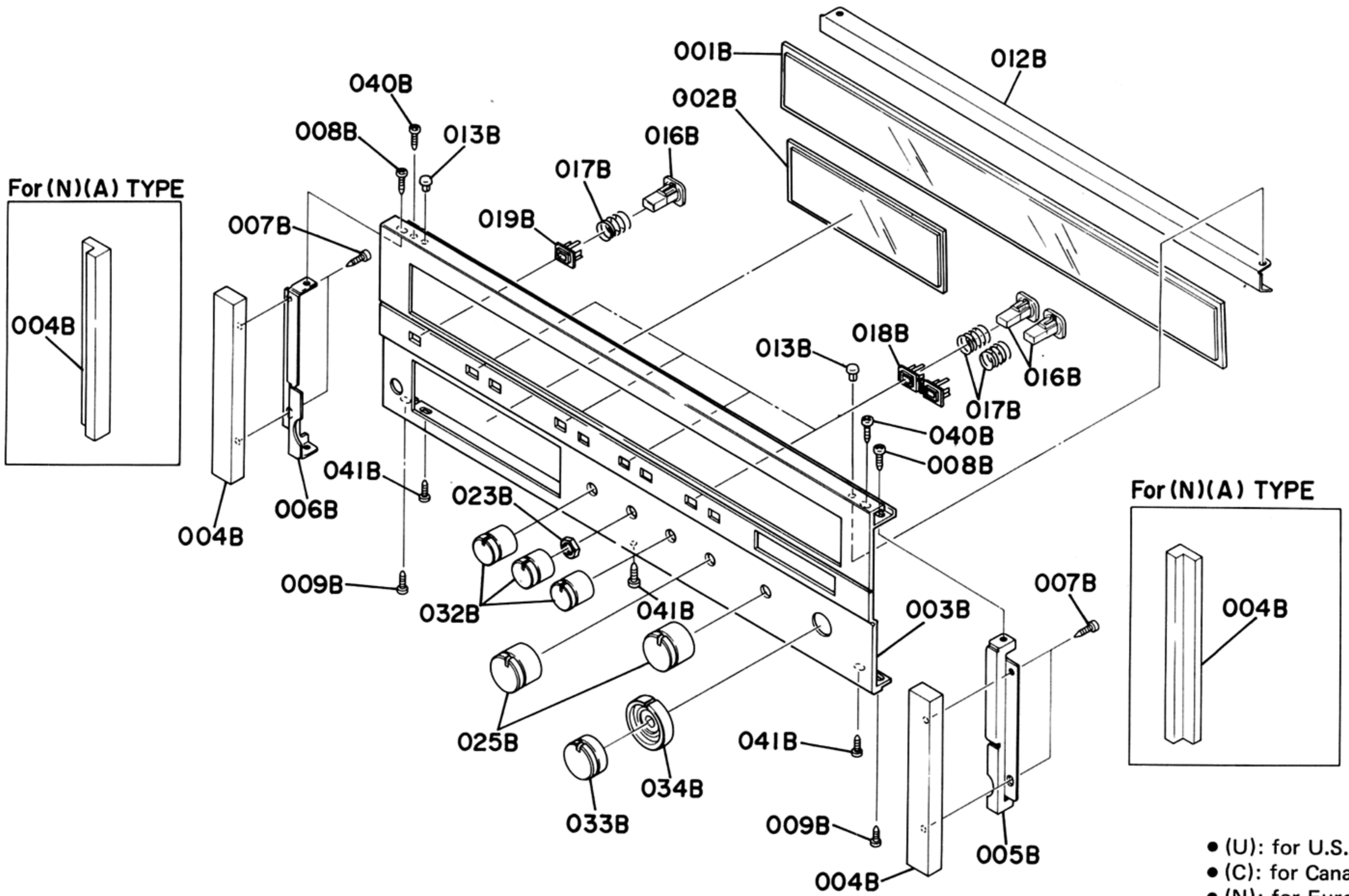

- (U): for U.S.A.
- (C): for Canada
- (N): for Europe
- (A): for Australia

REF. DESIG.	Q'TY				PART NO.	DESCRIPTION
	U	C	N	A		
A	1	1			2116063400	Front Panel Assembly
A1			1	1	2116063410	Front Panel Assembly
001B	1	1	1	1	2112158110	Window, Dial
002B	1	1	1	1	2112158120	Window, Meter
003B	1	1	1	1	2116063013	Escutcheon
004B	2	2			2112063044	Escutcheon, Wood
004B			2	2	2112063052	Escutcheon, AL
005B	1	1	1	1	2112160020	Bracket (R)
006B	1	1	1	1	2112160030	Bracket (L)
007B	4	4			51400310A0	B.H. Tapped Screw B3 x 10
007B			4	4	51280306B0	B.H. Tapped Screw B3 x 6
008B	2	2	2	2	51280308B0	B.H. Tapped Screw B3 x 8
009B	2	2	2	2	51280308B0	B.H. Tapped Screw B3 x 8
012B	1	1	1	1	2112303010	Mask
013B	2	2	2	2	2276005050	Clamper
018B	4	4	4	4	2112259020	Bushing
019B	1	1	1	1	2112259030	Bushing

REF. DESIG.	Q'TY				PART NO.	DESCRIPTION
	U	C	N	A		
016B	9	9	9	9	2112154010	Knob
017B	9	9	9	9	2112115010	Spring
023B	1	1	1	1	53118169A0	Hexagon Nut
025B	2	2	2	2	2112154020	Knob
032B	3	3	3	3	2116154010	Knob
033B	1	1	1	1	2112154030	Knob
034B	1	1	1	1	2112154040	Knob
040B	2	2	2	2	51100308A9	B.H.M Screw B3 x 8
041B	3	3	3	3	51280308B0	B.H. Tapped Screw B3 x 8

6.2 [C02-99] TOP COVER

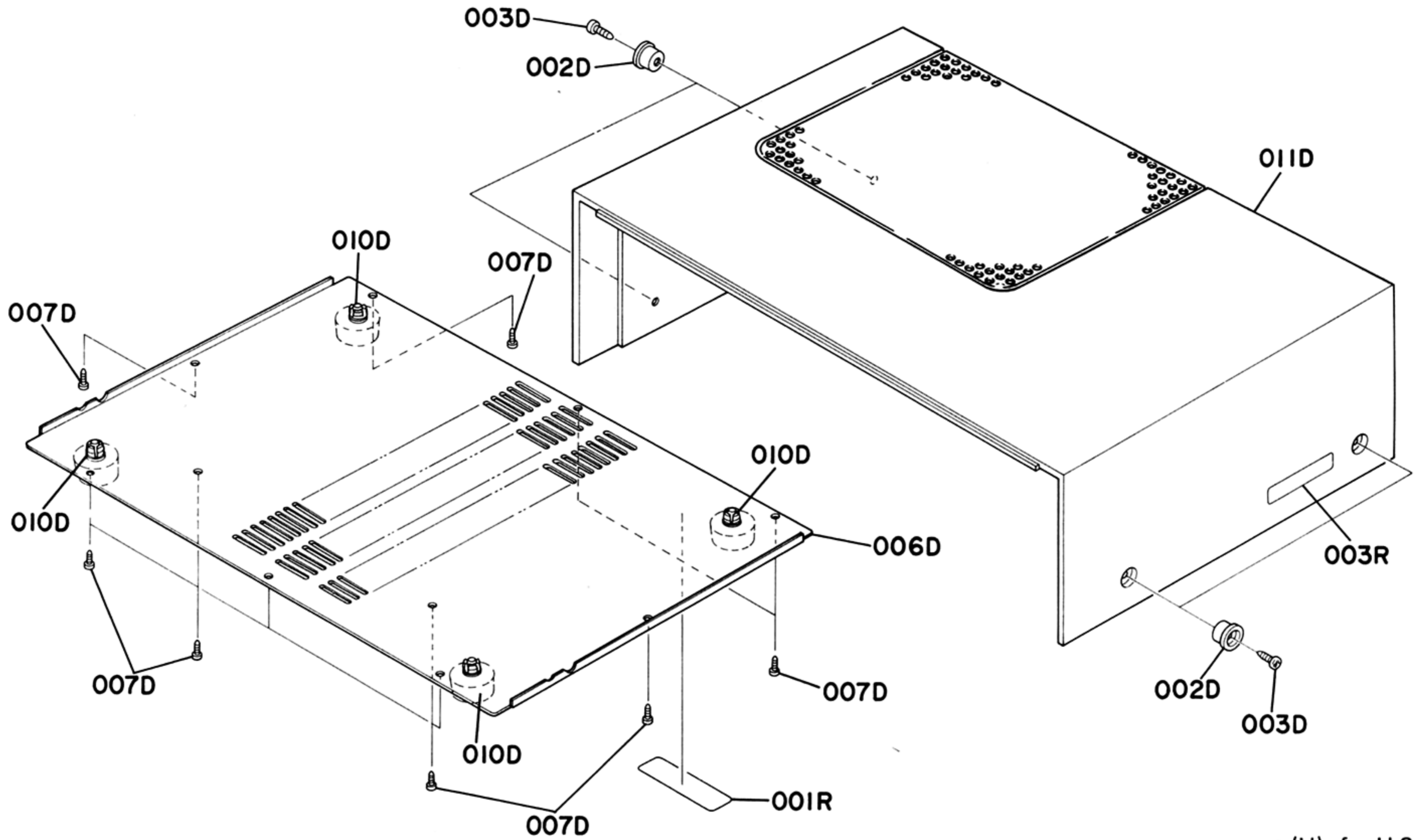

- (U): for U.S.A.
- (C): for Canada
- (N): for Europe
- (A): for Australia

REF. DESIG.	Q'TY				PART NO.	DESCRIPTION
	U	C	N	A		
002D	4	4	4	4	3906259010	Bushing
003D	4	4	4	4	51280414U0	B.H. Tapped Screw B4 x 14
006D	1	1	1	1	2116257010	Lid, Bottom Cover
007D	12	12	12	12	51280410B0	B.H. Tapped Screw B4 x 10
010D	4	4	4	4	2259057012	Leg
011D	1	1	1	1	2116064500	Case, Wood K

REF. DESIG.	Q'TY				PART NO.	DESCRIPTION
	U	C	N	A		
001R	1		1	1	2578861010	Label
001R		1			2911861112	Label
003R	1		1	1	2932861012	Label
003R		1			2911861143	Label

6.3 [C03-99] REAR PANEL

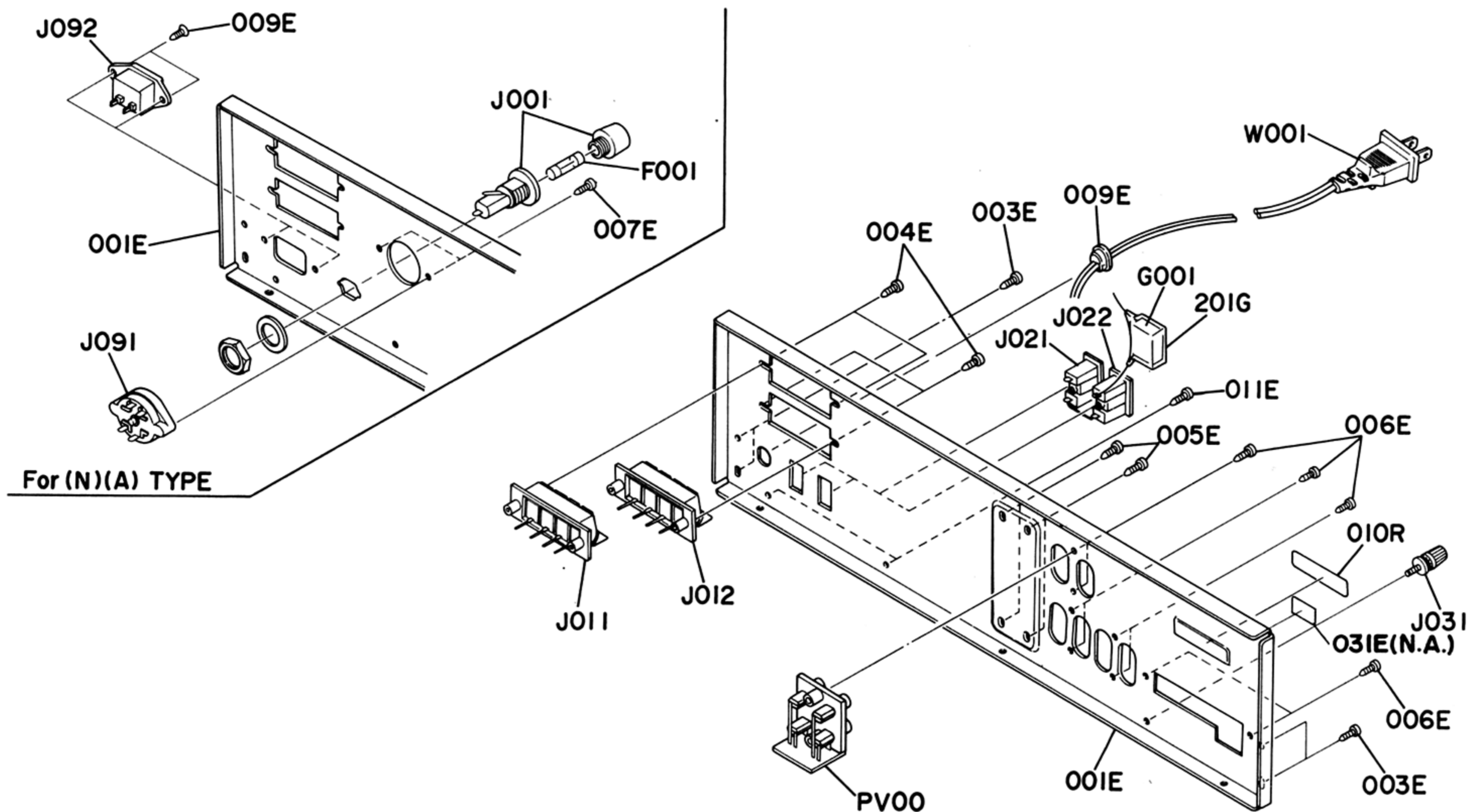

- (U): for U.S.A.
- (C): for Canada
- (N): for Europe
- (A): for Australia

REF. DESIG.	Q'TY				PART NO.	DESCRIPTION
	U	C	N	A		
001E	1				2116160212	Bracket
001E		1			2116160232	Bracket
001E			1	1	2116160223	Bracket
003E	4	4	4	4	51280308U0	B.H. Tapped Screw B3 x 8
004E	4	4	4	4	51280308U0	B.H. Tapped Screw B3 x 8
005E	4	4	4	4	51280308U0	B.H. Tapped Screw B3 x 8
006E	8	8	8	8	51280308U0	B.H. Tapped Screw B3 x 8
007E			2	2	51280308U0	B.H. Tapped Screw B3 x 8
009E	1	1			1455259030	Bushing
009E			2	2	51420308T0	O.C.H. Tapped Screw 3 x 8
011E	2	2	2	2	51280308U0	B.H. Tapped Screw B3 x 8
031E			1	1	4581861010	Label
201G	1	1			3941120050	Insulator
G001	1				BF10400030	Spark Killer 0.1uF + 120Ω
G001		1			BF10400050	Spark Killer 0.1uF + 120Ω

REF. DESIG.	Q'TY				PART NO.	DESCRIPTION
	U	C	N	A		
△F001			1	1	FS10250800	Fuse 2.5AT 250V
△J001			1	1	YJ08000290	Jack, Fuse Holder
J011	1	1	1	1	YT03040170	Terminal, Speaker
J012	1	1	1	1	YT03040170	Terminal, Speaker
△J021	1	1			YJ04000560	Jack, AC Outlet
△J022	1	1			YJ04000560	Jack, AC Outlet
J031	1	1	1	1	YL03010240	Terminal, Ground
△J091			1	1	BY05080012	Plug, Voltage Selector
△J092			1	1	YP04000590	Plug, AC Inlet
△W001	1	1			YC02000150	A.C. Power Cord
010R	1	1	1	1	2112265010	Indicator

6.5 [P02-99] CHASSIS AND OTHER PARTS

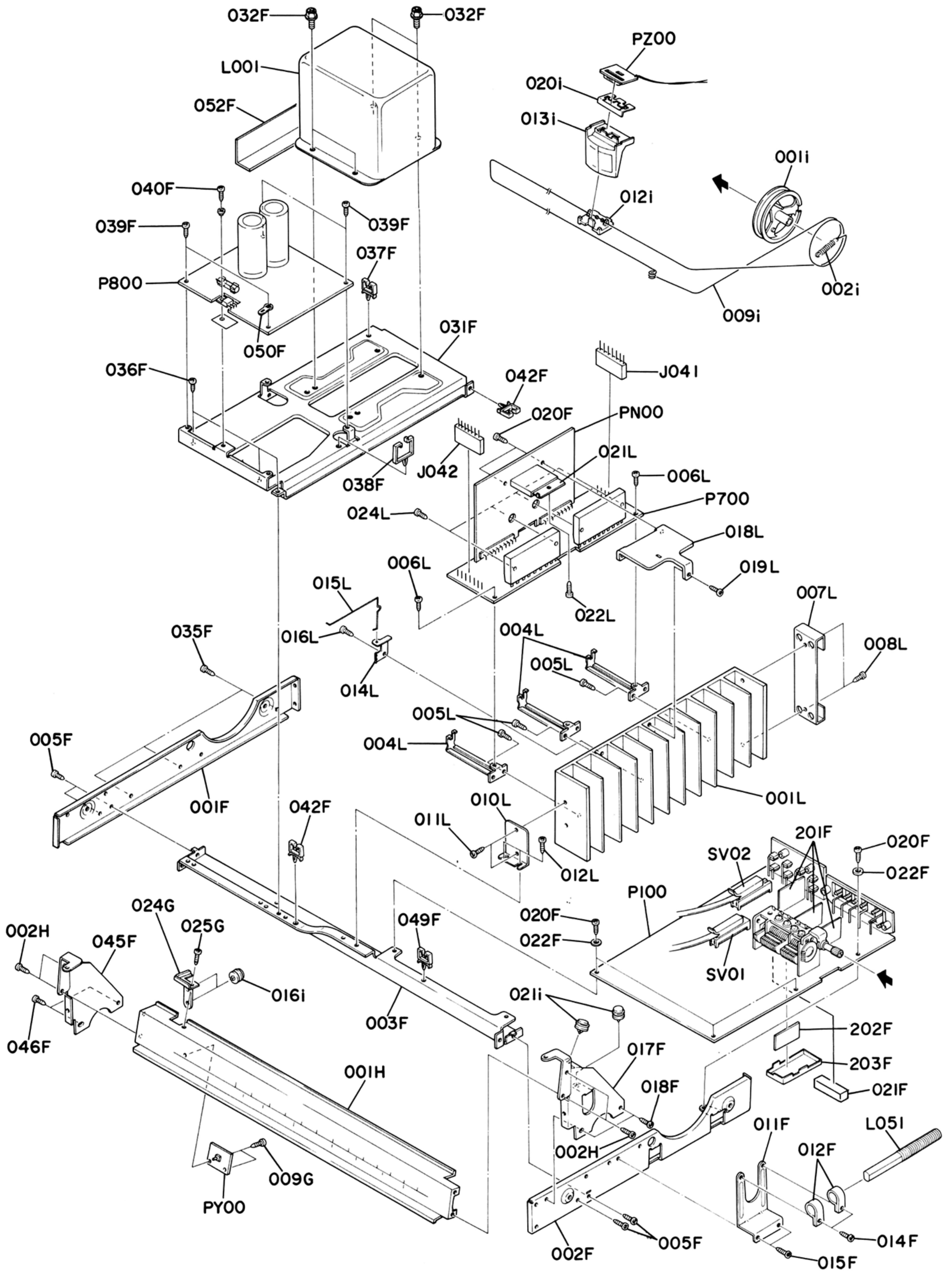

- (U): for U.S.A.
- (C): for Canada
- (N): for Europe
- (A): for Australia

REF. DESIG.	Q'TY				PART NO.	DESCRIPTION
	U	C	N	A		
001F	1	1	1	1	2116126010	Stay (L)
002F	1	1	1	1	2116126020	Stay (R)
003F	1	1	1	1	2116126030	Stay, Center
005F	4	4	4	4	51280308B0	B.H. Tapped Screw B3 x 8
011F	1	1	1	1	2112271010	Holder
012F	2	2	2	2	1502271010	Holder
014F	2	2	2	2	51260310B0	B.H. Tapped Screw B3 x 10
015F	2	2	2	2	51280308B0	B.H. Tapped Screw B3 x 8
017F	1	1	1	1	2116160052	Bracket (R)
018F	2	2	2	2	51280308B0	B.H. Tapped Screw B3 x 8
020F	4	4	4	4	51260308B0	B.H. Tapped Screw B3 x 8
022F	4	4	4	4	54110009A0	Flat Washer, P.
031F	1	1	1	1	2116004012	Table
032F	4	4	4	4	52040410A0	H. Head Bolt, S.F H4 x 10
035F	3	3	3	3	51280308B0	B.H. Tapped Screw B3 x 8
036F	3	3	3	3	51280308B0	B.H. Tapped Screw B3 x 8
037F	1	1	1	1	2886005052	Clamper
038F	1	1	1	1	2886005020	Clamper
039F	4	4	4	4	51260308B0	B.H. Tapped Screw B3 x 8
040F	1	1	1	1	51100308A9	B.H. M. Screw B3 x 8
042F	2	2	2	2	2886005020	Clamper
045F	1	1	1	1	2116160062	Bracket
046F	2	2	2	2	51280308B0	B.H. Tapped Screw B3 x 8
049F	1	1	1	1	2886005020	Clamper
050F	1	1	1	1	62030039W0	Lug
052F	1	1	1	1	2116118010	Spacer
201F	3	3	3	3	2259109040	Shield
202F	1	1	1	1	2259109060	Shield
203F	1	1	1	1	2112109010	Shield
009G	2	2	2	2	51282605B0	B.H. Tapped Screw B2.6 x 5
024G	1	1	1	1	2112160072	Bracket
025G	1	1	1	1	51280308B0	B.H. Tapped Screw B3 x 8
001i	1	1	1	1	2112159010	Drum
002i	1	1	1	1	71101689L0	Spring
009i	1	1	1	1	72040805A0	String (180)
012i	1	1	1	1	2112103012	Pointer
013i	1	1	1	1	2112103022	Pointer
016i	2	2	2	2	2276262500	Pulley
020i	1	1	1	1	2112303033	Mask
021i	2	2	2	2	2276262500	Pulley
001H	1	1	1	1	2116302010	Dial
002H	4	4	4	4	51280308B0	B.H. Tapped Screw B3 x 8
003H	2	2	2	2	2276005050	Clamper
021F	1	1	1	1	2116056012	Buffer

REF. DESIG.	Q'TY				PART NO.	DESCRIPTION
	U	C	N	A		
001L	1	1	1	1	2116267110	Heatsink
004L	2	2	2	2	2116160040	Bracket
005L	2	2	2	2	51280308B0	B.H. Tapped Screw B3 x 8
006L	2	2	2	2	51260308B0	B.H. Tapped Screw B3 x 8
007L	1	1	1	1	2116160072	Bracket
008L	2	2	2	2	51280308B0	B.H. Tapped Screw B3 x 8
010L	1	1	1	1	2276160040	Bracket
011L	2	2	2	2	51280308B0	B.H. Tapped Screw B3 x 8
012L	2	2	2	2	51280308B0	B.H. Tapped Screw B3 x 8
014L	1	1	1	1	2112271020	Holder
015L	1	1	1	1	2116272013	Pole
016L	1	1	1	1	51280308B0	B.H. Tapped Screw B3 x 8
018L	1	1	1	1	2116267020	Heatsink
019L	1	1	1	1	51280310B0	B.H. Tapped Screw B3 x 10
020L	2	2	2	2	51260308B0	B.H. Tapped Screw B3 x 8
021L	1	1	1	1	2116115010	Spring
022L	1	1	1	1	51280308B0	B.H. Tapped Screw B3 x 8
024L	4	4	4	4	51260316B0	B.H. Tapped Screw B3 x 16
△L001	1				TS18505010	Power Transformer
△L001		1			TS18505020	Power Transformer
△L001			1	1	TS19611010	Power Transformer
L051	1				LF11000250	Antenna Coil
L051		1	1	1	LF11000240	Antenna Coil
J041	1	1	1	1	YJ06001060	Jack (7P)
J042	1	1	1	1	YJ06001060	Jack (7P)
SV01	1	1	1	1	SS04040030	Slide Switch, Selector
SV02	1	1	1	1	SS04060010	Slide Switch, Rec. Mode

6.6 [H01-99] PACKING MATERIALS

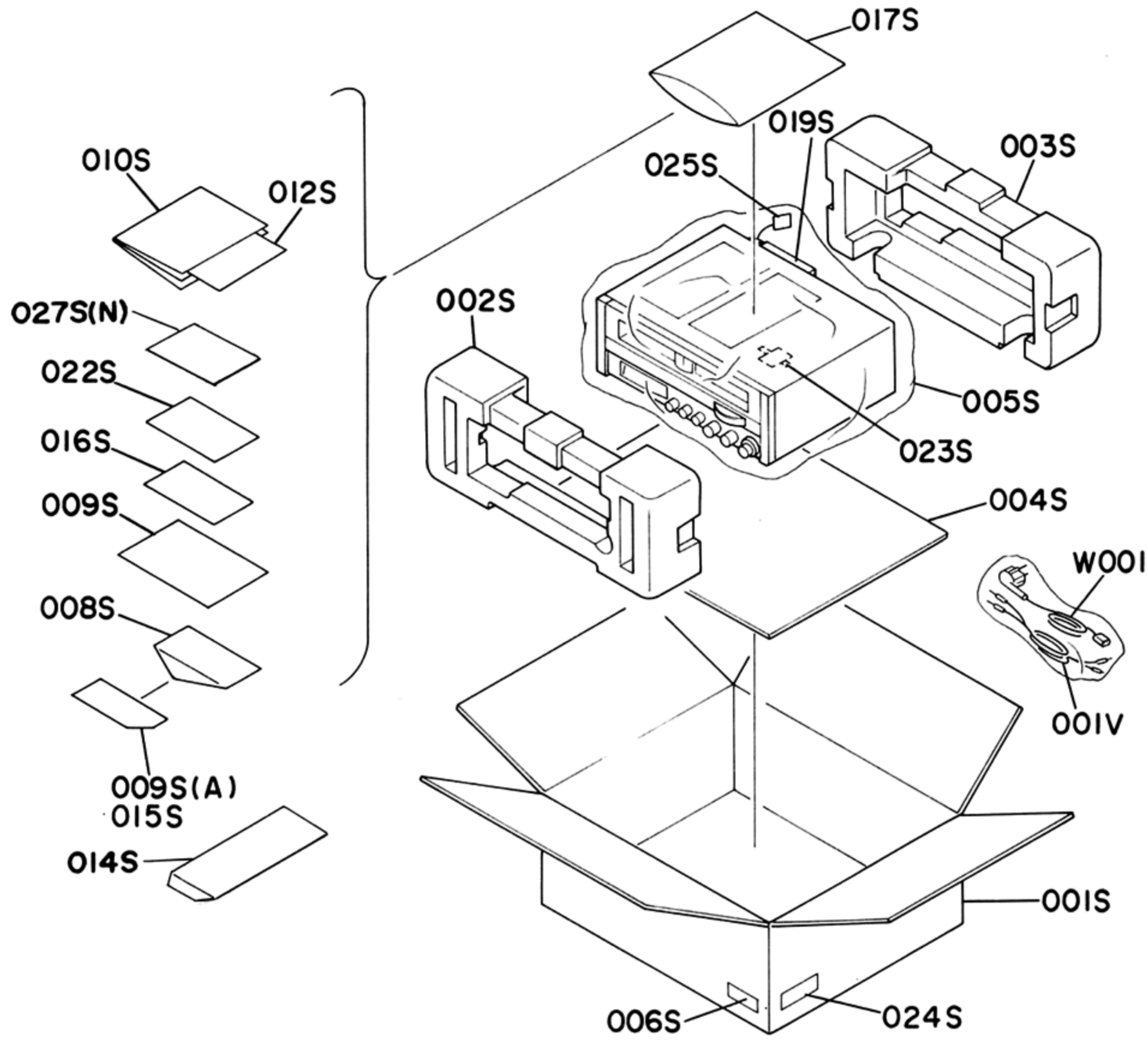

- (U): for U.S.A.
- (C): for Canada
- (N): for Europe
- (A): for Australia

REF. DESIG.	Q'TY				PART NO.	DESCRIPTION
	U	C	N	A		
001S			1	1	2116801020	Packing Case
001S	1	1	1	1	2116801012	Packing Case
002S	1	1	1	1	2112809012	Cushion
003S	1	1	1	1	2112809020	Cushion
004S	1	1	1	1	2918107260	Sheet
005S	1	1	1	1	9090909040	Polyethy Sheet
006S	3				9526019010	Serial NO. Card
006S		3			9226019020	Serial NO. Card
006S			3	3	9526019060	Serial NO. Card
008S		1			2918813012	Envelope
009S	1				2818854026	Guarantee Card
009S		1			2818854042	Guarantee Card
009S				1	9631000090	Guarantee Card
010S	1				2116851012	Instructions
010S		1	1	1	2112851310	Instructions
012S	1			1	2116851020	Instructions
012S		1			2116851050	Instructions
012S			1		2116851030	Instructions
014S	1				2225813012	Envelope

REF. DESIG.	Q'TY				PART NO.	DESCRIPTION
	U	C	N	A		
015S		1			9630000180	Guarantee Card
016S		1			9650000053	S. Station Card
017S	1	1	1	1	9013025010	Polyethy Bag
019S	1	1	1	1	2864804010	Sleeve
022S		1			2886851100	Instruction
023S			1	1	2731821012	Silicagel
024S		2			9510901020	Label
025S			1	1	9560000043	Hang Tag
027S			1		2116856010	Circuit Diagram
001V	1	1	1	1	ZA02000070	EXT. Antenna
△W001			1		ZC01805020	A.C. Power Cord
△W001				1	ZC02006030	A.C. Power Cord

6.7 ELECTRICAL PARTS

- (U): for U.S.A.
- (C): for Canada
- (N): for Europe
- (A): for Australia

REF. DESIG.	Q'TY				PART NO.	DESCRIPTION
	U	C	N	A		
P100	1	1	1	1	YK21161710	P100-TUNER/PHONO CIRCUIT BOARD P.W. Board, Tuner/Phono
	1	1			ZZ21161710	P.W. Board Assembly
			1	1	ZZ21168710	P.W. Board Assembly
P100-CAPACITORS						
CA01	1	1	1	1	DA17103010	Ceramic 0.01 μ F \pm 30%
CA02	1	1	1	1	DF55391090	Film 390pF \pm 5%
CA03	1	1	1	1	DA15150010	Ceramic 15pF \pm 5%
CA04	1	1	1	1	DA17103010	Ceramic 0.01 μ F \pm 30%
CA05	1	1	1	1	DA17103010	Ceramic 0.01 μ F \pm 30%
CA06	1	1	1	1	DA15470010	Ceramic 47pF \pm 5%
CA07	1	1	1	1	DA17103010	Ceramic 0.01 μ F \pm 30%
CA08	1	1	1	1	EA10701690	Elect 100 μ F 16V
CA09	1	1	1	1	DK18403320	Ceramic 0.04 μ F
CA10	1	1	1	1	DK17103300	Ceramic 0.01 μ F \pm 20%
CA11	1	1	1	1	DA17103010	Ceramic 0.01 μ F \pm 30%
CA12	1	1	1	1	EA10601690	Elect 10 μ F 16V
CA13	1	1	1	1	EA10602530	Elect 10 μ F 25V
CA14	1	1	1	1	DA17103010	Ceramic 0.01 μ F \pm 30%
CA15	1	1	1	1	DA17103010	Ceramic 0.01 μ F \pm 30%
CA16	1	1	1	1	EA22405030	Elect 0.22 μ F 50V
CA17	1	1	1	1	EA10505090	Elect 1 μ F 50V
CA18	1	1	1	1	DK18223310	Ceramic 0.022 μ F
CA19	1	1	1	1	EA22505030	Elect 2.2 μ F 50V
CA20	1	1	1	1	EA22601630	Elect 22 μ F 16V
C101	1	1	1	1	DD15150370	Ceramic 15pF \pm 5%
C102	1	1	1	1	DA17103010	Ceramic 0.01 μ F \pm 30%
C103	1	1	1	1	DK17103300	Ceramic 0.01 μ F \pm 20%
C104	1	1	1	1	DA17103010	Ceramic 0.01 μ F \pm 30%
C105	1	1	1	1	DD15150370	Ceramic 15pF \pm 5%
C106	1	1	1	1	DD10030370	Ceramic 3pF \pm 0.25pF
C107	1	1	1	1	DD10050370	Ceramic 5pF \pm 0.25pF
C108	1	1	1	1	DA16331010	Ceramic 330pF \pm 20%
C109	1	1	1	1	DA17103010	Ceramic 0.01 μ F \pm 30%
C110	1	1	1	1	CA32400100	Variable FM-3, AM-2
C111	1	1	1	1	CT11000080	Trimming 10pF
C112	1	1	1	1	DD10010300	Ceramic 1pF \pm 0.25pF
C113	1	1	1	1	DD15150340	Ceramic 15pF \pm 5%
C114	1	1	1	1	DD11100300	Ceramic 10pF \pm 0.5pF
C115	1	1	1	1	DD15300300	Ceramic 30pF \pm 5%
C116	1	1	1	1	DD15150300	Ceramic 15pF \pm 5%
C117	1	1	1	1	DA17103010	Ceramic 0.01 μ F \pm 30%
C118	1	1	1	1	DA17103010	Ceramic 0.01 μ F \pm 30%
C119	1	1	1	1	DA17103010	Ceramic 0.01 μ F \pm 30%
C120	1	1	1	1	DA17103010	Ceramic 0.01 μ F \pm 30%
C121	1	1	1	1	DA17103010	Ceramic 0.01 μ F \pm 30%
C122	1	1	1	1	DK18403320	Ceramic 0.04 μ F
C123	1	1	1	1	DK18403320	Ceramic 0.04 μ F
C124	1	1	1	1	EA10505090	Elect 1 μ F 50V
C125	1	1	1	1	DA16331010	Ceramic 330pF \pm 10%
C126	1	1	1	1	DK18403320	Ceramic 0.04 μ F
C127	1	1	1	1	EA10505090	Elect 1 μ F 50V
C128	1	1	1	1	DK18403320	Ceramic 0.04 μ F
C129	1	1	1	1	EA10701630	Elect 100 μ F 16V
C130	1	1	1	1	DK18403320	Ceramic 0.04 μ F

REF. DESIG.	Q'TY				PART NO.	DESCRIPTION
	U	C	N	A		
C131	1	1	1	1	DK18403320	Ceramic 0.04 μ F
C132	1	1	1	1	DK18403320	Ceramic 0.04 μ F
C133	1	1	1	1	DK18403320	Ceramic 0.04 μ F
C134	1	1	1	1	EA10505030	Elect 1 μ F 50V
C136	1	1	1	1	DK18403320	Ceramic 0.04 μ F
C137	1	1	1	1	DK18104010	Ceramic 0.1 μ F
C138	1	1	1	1	DK18403320	Ceramic 0.04 μ F
C139	1	1	1	1	EA22700690	Elect 220 μ F 6.3V
C301	1	1	1	1	EA47505030	Elect 4.7 μ F 50V
C302	1	1	1	1	DF65501010	Film 500pF \pm 5%
C303	1	1	1	1	DF15473300	Film 0.047 μ F \pm 5%
C304	1	1	1	1	EQ10505010	Elect 1 μ F 50V
C305	1	1	1	1	EV68501060	Elect 6.8 μ F 10V
C306	1	1	1	1	DF65821010	Film 820pF \pm 5%
C307	1	1	1	1	EQ10505010	Elect 1 μ F 50V
C308	1	1	1	1	EA10505030	Elect 1 μ F 50V
C309	1	1	1	1	EA10701630	Elect 100 μ F 16V
C310	1	1	1	1	EA10701630	Elect 100 μ F 16V
C311	1	1	1	1	EA10505030	Elect 1 μ F 50V
C312	1	1	1	1	EA10505030	Elect 1 μ F 50V
C313	1	1			DF15332300	Film 3300pF \pm 5%
C313			1	1	DF15222300	Film 2200pF \pm 5%
C314	1	1			DF15332300	Film 3300pF \pm 5%
C314			1	1	DF15222300	Film 2200pF \pm 5%
C315	1	1	1	1	EA10405030	Elect 0.1 μ F 50V
C316	1	1	1	1	EA10405030	Elect 0.1 μ F 50V
C317	1	1	1	1	DA15101010	Ceramic 100pF \pm 5%
C318	1	1	1	1	DA15101010	Ceramic 100pF \pm 5%
C319	1	1	1	1	EA47505030	Elect 4.7 μ F 50V
C320	1	1	1	1	EA47505030	Elect 4.7 μ F 50V
C321	1	1	1	1	EA47601030	Elect 47 μ F 10V
C322	1	1	1	1	EA47505030	Elect 4.7 μ F 50V
C401	1	1	1	1	EE33502540	Elect 3.3 μ F 25V
C402	1	1	1	1	EE33502540	Elect 3.3 μ F 25V
C403	1	1	1	1	DA15221010	Ceramic 220pF \pm 5%
C404	1	1	1	1	DA15221010	Ceramic 220pF \pm 5%
C405	1	1	1	1	EA47601030	Elect 47 μ F \pm 20%
C406	1	1	1	1	EA47601030	Elect 47 μ F \pm 20%
C407	1	1	1	1	DA15101010	Ceramic 100pF \pm 5%
C408	1	1	1	1	DA15101010	Ceramic 100pF \pm 5%
C409	1	1	1	1	DF15182300	Film 1800pF \pm 5%
C410	1	1	1	1	DF15182300	Film 1800pF \pm 5%
C411	1	1	1	1	DF15682300	Film 6800pF \pm 5%
C412	1	1	1	1	DF15682300	Film 6800pF \pm 5%
C413	1	1	1	1	DA15100010	Ceramic 10pF \pm 5%
C414	1	1	1	1	DA15100010	Ceramic 10pF \pm 5%
C415	1	1	1	1	EA47505030	Elect 4.7 μ F 50V
C416	1	1	1	1	EA47505030	Elect 4.7 μ F 50V
C417	1	1	1	1	EA10702530	Elect 100 μ F 25V
C421	1	1	1	1	DK17103300	Ceramic 0.01 μ F 50V

- (U): for U.S.A.
- (C): for Canada
- (N): for Europe
- (A): for Australia

REF. DESIG.	Q'TY				PART NO.	DESCRIPTION
	U	C	N	A		
P100-RESISTORS (All Resistors are $\pm 5\%$ & $\frac{1}{4}W$)						
RA01	1	1	1	1	GD05102140	1K Ω
RA02	1	1	1	1	GD05222140	2.2K Ω
RA03	1	1	1	1	GG05101140	100 Ω
RA04	1	1	1	1	GD05273140	27K Ω
RA05	1	1	1	1	GD05563140	56K Ω
RA06	1	1	1	1	GD05333140	33K Ω
RA07	1	1	1	1	GD05102140	1K Ω
RA08	1	1	1	1	GD05222140	2.2K Ω
RA09	1	1	1	1	GD05103140	10K Ω
RA10	1	1	1	1	GD05103140	10K Ω
RA12	1	1	1	1	GD05473140	47K Ω
RA13	1	1	1	1	GD05103140	10K Ω
RA14	1	1	1	1	GD05103140	10K Ω
RA15	1	1	1	1	GD05223140	22K Ω
RA17	1	1	1	1	GD05473140	47K Ω
R101	1	1	1	1	GD05105140	1M Ω
R102	1	1	1	1	GD05101140	100 Ω
R103	1	1	1	1	GD05101140	100 Ω
R104	1	1	1	1	GD05101140	100 Ω
R105	1	1	1	1	GD05104140	100K Ω
R106	1	1	1	1	GD05223140	22K Ω
R107	1	1	1	1	GD05472140	4.7K Ω
R108	1	1	1	1	GD05102140	1K Ω
R109	1	1	1	1	GD05183140	18K Ω
R110	1	1	1	1	GG05101140	100 Ω
R111	1	1	1	1	GD05103140	10K Ω
R112	1	1	1	1	GD05103140	10K Ω
R113	1	1	1	1	GD05272140	2.7K Ω
R114	1	1	1	1	GD05331140	330 Ω
R115	1	1	1	1	GD05153140	15K Ω
R116	1	1	1	1	GD05272140	2.7K Ω
R117	1	1	1	1	GD05331140	330 Ω
R118	1	1	1	1	GD05102140	1K Ω
R119	1	1	1	1	GG05101140	100 Ω
R120	1	1	1	1	GD05331140	330 Ω
R121	1	1	1	1	GD05473140	47K Ω
R122	1	1	1	1	GD05123140	12K Ω
R123	1	1	1	1	GD05103140	10K Ω
R124	1	1	1	1	GD05103140	10K Ω
R125	1	1	1	1	GD05183140	18K Ω
R126	1	1	1	1	GD05332140	3.3K Ω
R127	1	1	1	1	GD05222140	2.2K Ω
R128	1	1	1	1	GD05103140	10K Ω
R129	1	1	1	1	GD05473140	47K Ω
R130	1	1	1	1	GD05821140	820 Ω
R131	1	1	1	1	RA01030260	10K Ω Trimming
R132	1	1	1	1	GD05474140	470K Ω
R133	1	1	1	1	GD05331140	330 Ω
R134	1	1	1	1	GD05183140	18K Ω
R135	1	1	1	1	GD05123140	12K Ω
R136	1	1	1	1	GD05822140	8.2K Ω
R138	1	1	1	1	GD05123140	12K Ω
R140	1	1	1	1	GG05470140	47 Ω
R301	1	1	1	1	GD05224140	220K Ω
R302	1	1	1	1	RA04720080	4.7K Ω Trimming
R303	1	1	1	1	GD05153140	15K Ω
R304	1	1	1	1	GD05821140	820 Ω
R305	1	1	1	1	GD05102140	1K Ω

REF. DESIG.	Q'TY				PART NO.	DESCRIPTION
	U	C	N	A		
R306	1	1	1	1	RA05020160	5K Ω Trimming
R307	1	1	1	1	GD05103140	10K Ω
R308	1	1	1	1	GD05154140	150K Ω
R309	1	1	1	1	GD05473140	47K Ω
R310	1	1	1	1	GD05102140	1K Ω
R311	1	1	1	1	GD05473140	47K Ω
R312	1	1	1	1	GG05470140	47 Ω
R313	1	1	1	1	GD05472140	4.7K Ω
R314	1	1	1	1	GD05472140	4.7K Ω
R315	1	1	1	1	GD05472140	4.7K Ω
R316	1	1	1	1	GD05472140	4.7K Ω
R317	1	1	1	1	GD05273140	27K Ω
R318	1	1	1	1	GD05273140	27K Ω
R319	1	1	1	1	GD05224140	220K Ω
R320	1	1	1	1	GD05224140	220K Ω
R321	1	1	1	1	GD05155140	1.5M Ω
R322	1	1	1	1	GD05155140	1.5M Ω
R323	1	1	1	1	GD05184140	180K Ω
R324	1	1	1	1	GD05184140	180K Ω
R325	1	1	1	1	GD05102140	1K Ω
R326	1	1	1	1	RA01030260	10K Ω Trimming
R327	1	1	1	1	GD05103140	10K Ω
R328	1	1	1	1	GD05103140	10K Ω
R329	1	1	1	1	GD05471140	470 Ω
R330	1	1	1	1	GD05471140	470 Ω
R331	1	1	1	1	GD05472140	4.7K Ω
R332	1	1	1	1	GD05472140	4.7K Ω
R333	1	1	1	1	GD05473140	47K Ω
R334	1	1	1	1	GD05473140	47K Ω
R335	1	1	1	1	GD05471140	470 Ω
R336	1	1	1	1	GD05471140	470 Ω
R337	1	1	1	1	GG05101140	100 Ω
R338	1	1	1	1	GD05473140	47K Ω
R339	1	1	1	1	GD05333140	33K Ω
R340	1	1	1	1	GD05274140	270K Ω
R341	1	1	1	1	GD05104140	100K Ω
R342	1	1	1	1	GD05103140	10K Ω
R343	1	1	1	1	GD05103140	10K Ω
R344	1	1	1	1	GD05103140	10K Ω
R401	1	1	1	1	GD05823140	82K Ω
R402	1	1	1	1	GD05823140	82K Ω
R403	1	1	1	1	GD05222140	2.2K Ω
R404	1	1	1	1	GD05222140	2.2K Ω
R405	1	1	1	1	GD05104140	100K Ω
R406	1	1	1	1	GD05104140	100K Ω
R407	1	1	1	1	GD05121140	120 Ω
R408	1	1	1	1	GD05121140	120 Ω
R409	1	1	1	1	GD05471140	470 Ω
R410	1	1	1	1	GD05471140	470 Ω
R411	1	1	1	1	GD05393140	39K Ω
R412	1	1	1	1	GD05393140	39K Ω
R413	1	1	1	1	GD05474140	470K Ω
R414	1	1	1	1	GD05474140	470K Ω
R415	1	1	1	1	GD05102140	1K Ω
R416	1	1	1	1	GD05102140	1K Ω
R417	1	1	1	1	GD05221140	220 Ω
R418	1	1	1	1	GD05221140	220 Ω
R419	1	1	1	1	GD05104140	100K Ω
R420	1	1	1	1	GD05104140	100K Ω
R421	1	1	1	1	GD05151140	150 Ω
R422	1	1	1	1	GD05151140	150 Ω

- (U): for U.S.A.
- (C): for Canada
- (N): for Europe
- (A): for Australia

REF. DESIG.	Q'TY				PART NO.	DESCRIPTION
	U	C	N	A		
P100-SEMICONDUCTORS						
QA01	1	1	1	1	HC10025060	IC μ PC1178C
QA02	1	1	1	1	HV00006120	Varistor MV-203
QA03	1	1	1	1	HD20011050	Diode 1S1555
QA04	1	1	1	1	HT326342B0	Transistor 2SC2634
Q101	1	1	1	1	HF400451B0	F.E.T. 3SK45(B)
Q102	1	1	1	1	HT310471C0	Transistor 2SC1047(C)
Q103	1	1	1	1	HT308291C0	Transistor 2SC829(C)
Q104	1	1	1	1	HT310471C0	Transistor 2SC1047(C)
Q105	1	1	1	1	HC10033010	IC HA11225
Q106	1	1	1	1	HD20011050	Diode 1S1555
Q107	1	1	1	1	HD20011050	Diode 1S1555
Q108	1	1	1	1	HD20011050	Diode 1S1555
Q301	1	1	1	1	HC10001420	IC KB4437
Q302	1	1	1	1	HD20011050	Diode 1S1555
Q303	1	1	1	1	HT326342B0	Transistor 2SC2634(S or T)
Q304	1	1	1	1	HT326342B0	Transistor 2SC2634(S or T)
Q305	1	1	1	1	HT326342B0	Transistor 2SC2634(S or T)
Q306	1	1	1	1	HT326342B0	Transistor 2SC2634(S or T)
Q307	1	1	1	1	HT111272B0	Transistor 2SA1127(S or T)
Q308	1	1	1	1	HT111272B0	Transistor 2SA1127(S or T)
Q309	1	1	1	1	HT326342B0	Transistor 2SC2634(S or T)
Q310	1	1	1	1	HT326342B0	Transistor 2SC2634(S or T)
Q311	1	1	1	1	HD20011050	Diode 1S1555
Q312	1	1	1	1	HD20011050	Diode 1S1555
Q401	1	1	1	1	HC10034010	IC HA1457W
Q402	1	1	1	1	HC10034010	IC HA1457W
P100-MISCELLANEOUS						
FA01	1	1	1	1	FF10045200	Ceramic Filter CF SFZ450B
F101	1	1	1	1	FF11070050	Ceramic Filter SFE10.7MD-1
F102	1	1			FF11070050	Ceramic Filter SFE10.7MD-1
F102			1	1	FF11070130	Ceramic Filter SFE10.7MS3G
F103	1	1			FF11070050	Ceramic Filter SFE10.7MD-1
F103			1	1	FF11070130	Ceramic Filter SFE10.7MS3G
JV01	1	1	1	1	YT02040280	Terminal, Phono/Aux
JV02	1	1	1	1	YT02040280	Terminal, Tape-1
J101	1	1	1	1	YT01050010	Terminal, Antenna
LA01	1	1	1	1	LO10010480	OSC Coil
LA02	1	1	1	1	LI10010730	I.F.T.
LA03	1	1	1	1	LI10010740	I.F.T.
LA04	1	1	1	1	LC11540020	Choke Coil 150 μ H
L101	1	1	1	1	LA12028040	Antenna Coil
L102	1	1	1	1	LL24800030	Coil
L103	1	1	1	1	LK11800030	Coil
L104	1	1	1	1	LC17510010	Choke Coil 0.75 μ H
L105	1	1	1	1	LI10016010	I.F.T.
L106	1	1	1	1	LO12036010	OSC Coil
L107	1	1	1	1	LC13320050	Choke Coil 3.3 μ H
L108	1	1	1	1	LC12230060	Choke Coil 22 μ H
L109	1	1	1	1	LI10156240	I.F.T.
L110	1	1	1	1	LI10156230	I.F.T.
L301	1	1	1	1	LS20010020	M.P.X. Coil 38KHz
SV01	1	1	1	1	SS04040030	Slide Switch, Selector
SV02	1	1	1	1	SS04060010	Slide Switch, Rec. Mode

REF. DESIG.	Q'TY				PART NO.	DESCRIPTION
	U	C	N	A		
P700-POWER AMP. CIRCUIT BOARD						
P700	1	1	1	1	YK21161810	P.W. Board, Power Amp.
	1	1	1	1	ZZ21161810	P.W. Board Assembly
P700-CAPACITORS						
C701	1	1	1	1	EA47706310	Elect 470 μ F 63V
C702	1	1	1	1	EA47706310	Elect 470 μ F 63V
C703	1	1	1	1	EA47706310	Elect 470 μ F 63V
C704	1	1	1	1	EA47706310	Elect 470 μ F 63V
C705	1	1	1	1	DF17473500	Film 0.047 μ F \pm 20%
C706	1	1	1	1	DF17473500	Film 0.047 μ F \pm 20%
C707	1	1	1	1	EA10602530	Elect 10 μ F 25V
C708	1	1	1	1	EA10602530	Elect 10 μ F 25V
C709	1	1	1	1	DF16473300	Film 0.047 μ F \pm 10%
C710	1	1	1	1	DF16473300	Film 0.047 μ F \pm 10%
C711	1	1	1	1	EA47601030	Elect 47 μ F 10V
C712	1	1	1	1	EA10701630	Elect 100 μ F 16V
P700-RESISTORS						
Δ R701	1	1	1	1	GO10332050	0.33 Ω 5W
Δ R702	1	1	1	1	GO10332050	0.33 Ω 5W
Δ R703	1	1	1	1	GO10332050	0.33 Ω 5W
Δ R704	1	1	1	1	GO10332050	0.33 Ω 5W
R705	1	1	1	1	RC10022120	2.2 Ω \pm 10% 1/2W
R706	1	1	1	1	RC10022120	2.2 Ω \pm 10% 1/2W
R707	1	1	1	1	GA05330030	33 Ω \pm 5% 3W
R708	1	1	1	1	GA05330030	33 Ω \pm 5% 3W
R709	1	1	1	1	GA05562010	5.6K Ω \pm 5% 1W
R710	1	1	1	1	GA05562010	5.6K Ω \pm 5% 1W
R711	1	1	1	1	GD05223140	22K Ω \pm 5% 1/4W
R712	1	1	1	1	GD05153140	15K Ω \pm 5% 1/4W
R713	1	1	1	1	GD05562140	5.6K Ω \pm 5% 1/4W
R714	1	1	1	1	GD05154140	150K Ω \pm 5% 1/4W
R715	1	1	1	1	GD05393140	39K Ω \pm 5% 1/4W
R716	1	1	1	1	GG05100140	10 Ω \pm 5% 1/4W
R717	1	1	1	1	GD05333140	33K Ω \pm 5% 1/4W
P700-SEMICONDUCTORS						
Δ Q701	1	1	1	1	HC10033030	IC STK-0080 Mark 2
Δ Q702	1	1	1	1	HC10033030	IC STK-0080 Mark 2
Q703	1	1	1	1	HD20005010	Diode W06B
Q704	1	1	1	1	HD20005010	Diode W06B
Q705	1	1	1	1	HD20005010	Diode W06B
Q706	1	1	1	1	HD20005010	Diode W06B
Δ Q707	1	1	1	1	HD20003210	Diode 1S2471
Q708	1	1	1	1	HD20011050	Diode 1S1555
Q709	1	1	1	1	HT314001E0	Transistor 2SC1400(E)
Q710	1	1	1	1	HT314001E0	Transistor 2SC1400(E)
Q711	1	1	1	1	HT405712B0	Transistor 2SD571(L or K)
P700-MISCELLANEOUS						
J701	1	1	1	1	YP06001060	Plug (7P)
J702	1	1	1	1	YP06001060	Plug (7P)
L701	1	1	1	1	LL23915120	Coil
L702	1	1	1	1	LL23915120	Coil
Δ L703	1	1	1	1	LY20200140	Relay

- (U): for U.S.A.
- (C): for Canada
- (N): for Europe
- (A): for Australia

REF. DESIG.	Q'TY				PART NO.	DESCRIPTION
	U	C	N	A		
P800	1	1	1	1	YK21161880	P800-POWER SUPPLY CIRCUIT BOARD P.W. Board, Power Supply
	1				ZZ21161880	P.W. Board Assembly
		1			ZZ21162880	P.W. Board Assembly
			1	1	ZZ21168880	P.W. Board Assembly
P800-CAPACITORS						
△ C801	1	1	1	1	EB10905610	Elect 10000μF 56V
△ C802	1	1	1	1	EB10905610	Elect 10000μF 56V
△ C803	1	1	1	1	DK18103510	Ceramic 0.01μF
△ C804	1	1	1	1	DK18103510	Ceramic 0.01μF
△ C805	1	1	1	1	EA10705090	Elect 100μF 50V
△ C806	1	1	1	1	EA10705090	Elect 100μF 50V
C807	1	1	1	1	EA10605030	Elect 10μF 50V
C808	1	1	1	1	EA10605030	Elect 10μF 50V
C809	1	1	1	1	EA33505030	Elect 3.3μF 50V
C810	1	1	1	1	EA33505030	Elect 3.3μF 50V
C811	1	1	1	1	DK18403320	Ceramic 0.04μF
C812	1	1	1	1	DK18403320	Ceramic 0.04μF
C813	1	1	1	1	EA10701690	Elect 100μF 16V
C814	1	1	1	1	EA33505090	Elect 3.3μF 50V
C815	1	1	1	1	EA33505090	Elect 3.3μF 50V
C816	1	1	1	1	EA10603530	Elect 10μF 35V
C817	1	1	1	1	EA10701630	Elect 100μF 16V
△ C818	1	1	1	1	EA10703590	Elect 100μF 35V
△ C819	1	1	1	1	EA10701630	Elect 100μF 16V
C820	1	1	1	1	DK18403320	Ceramic 0.04μF +100%-0
P800-RESISTORS (All Resistors are ±5% & ¼W)						
△ R801	1	1	1	1	RF05100140	10Ω Fusible
△ R802	1	1	1	1	RF05100140	10Ω Fusible
△ R803	1	1	1	1	GP05121030	120Ω 3W
R804	1	1	1	1	GD05103140	10KΩ
R805	1	1	1	1	GD05103140	10KΩ
R806	1	1	1	1	GD05472140	4.7KΩ
R807	1	1	1	1	GD05472140	4.7KΩ
R808	1	1	1	1	GD05472140	4.7KΩ
R809	1	1	1	1	GD05472140	4.7KΩ
R810	1	1	1	1	GD05182140	1.8KΩ
R811	1	1	1	1	GD05223140	22KΩ
R812	1	1	1	1	GD05332140	3.3KΩ
R813	1	1	1	1	GD05562140	5.6KΩ
R814	1	1	1	1	GD05102140	1KΩ
R815	1	1	1	1	GD05474140	470KΩ
R816	1	1	1	1	GD05223140	22KΩ
R817	1	1	1	1	GD05272140	2.7KΩ
R818	1	1	1	1	GD05272140	2.7KΩ
R820	1	1			RC10225120	2.2MΩ ±10% ½W
P800-SEMICONDUCTORS						
△ Q801	1	1	1	1	HD20011290	Diode S3VB-20
△ Q802	1	1	1	1	HD20011290	Diode S3VB-20
△ Q803	1	1	1	1	HD20011290	Diode S3VB-20
△ Q804	1	1	1	1	HD20011290	Diode S3VB-20
△ Q805	1	1	1	1	HD20005010	Diode W06B
△ Q806	1	1	1	1	HD20005010	Diode W06B
△ Q807	1	1	1	1	HD20005010	Diode W06B
△ Q808	1	1	1	1	HD20005010	Diode W06B
△ Q809	1	1	1	1	HD20005010	Diode W06B
△ Q810	1	1	1	1	HT326342A0	Transistor 2SC2634(R or S)

REF. DESIG.	Q'TY				PART NO.	DESCRIPTION
	U	C	N	A		
Q811	1	1	1	1	HT309452B0	Transistor 2SC945(P or Q)
△ Q812	1	1	1	1	HT403131Q0	Transistor 2SD313(E)
Q813	1	1	1	1	HD20011050	Diode 1S1555
Q814	1	1	1	1	HD30027090	Zener WZ-140
△ Q815	1	1	1	1	HT107202B0	Transistor 2SA720(Q or R)
△ Q816	1	1	1	1	HT111272A0	Transistor 2SA1127(R or S)
Q817	1	1	1	1	HD30027090	Zener WZ-140
Q818	1	1	1	1	HT107332A0	Transistor 2SA733(P or Q)
P800-MISCELLANEOUS						
△ F801	1				FS10500040	Fuse 5A 250V
△ F801		1			FS10500060	Fuse 5A 250V
F802			1	1	FS10050800	Fuse 0.5A 250V
J831			1	1	YJ08000270	Jack, Fuse Holder
J832			1	1	YJ08000270	Jack, Fuse Holder
J833	1	1			YJ08000170	Jack, Fuse Holder
J834	1	1			YJ08000170	Jack, Fuse Holder
PE00-TONE AMP. CIRCUIT BOARD						
PE00	1	1	1	1	YK21161850	P.W. Board, Tone Amp.
	1	1	1	1	ZZ21161850	P.W. Board Assembly
PE00-CAPACITORS						
CE01	1	1	1	1	EE10505040	Elect 1μF 50V
CE02	1	1	1	1	EE10505040	Elect 1μF 50V
CE03	1	1	1	1	DK16101300	Ceramic 100pF ±10%
CE04	1	1	1	1	DK16101300	Ceramic 100pF ±10%
CE05	1	1	1	1	EE22505040	Elect 2.2μF 50V
CE06	1	1	1	1	EE22505040	Elect 2.2μF 50V
CE07	1	1	1	1	DK16101300	Ceramic 100pF ±10%
CE08	1	1	1	1	DK16101300	Ceramic 100pF ±10%
CE09	1	1	1	1	DF16222300	Film 2200pF ±10%
CE10	1	1	1	1	DF16222300	Film 2200pF ±10%
CE11	1	1	1	1	DF16562300	Film 5600pF ±10%
CE12	1	1	1	1	DF16562300	Film 5600pF ±10%
CE15	1	1	1	1	DF16183300	Film 0.018μF ±10%
CE16	1	1	1	1	DF16183300	Film 0.018μF ±10%
CE17	1	1	1	1	DF16183300	Film 0.018μF ±10%
CE18	1	1	1	1	DF16183300	Film 0.018μF ±10%
CE19	1	1	1	1	DF16822300	Film 8200pF ±10%
CE20	1	1	1	1	DF16822300	Film 8200pF ±10%
CE21	1	1	1	1	DD15560370	Ceramic 56pF ±10%
CE22	1	1	1	1	DD15560370	Ceramic 56pF ±10%
CE23	1	1	1	1	EA33505030	Elect 3.3μF 50V
CE24	1	1	1	1	EA33505030	Elect 3.3μF 50V
PE00-RESISTORS (All Resistors are ±5% & ¼W)						
RE01	1	1	1	1	GD05683140	68KΩ
RE02	1	1	1	1	GD05683140	68KΩ
RE03	1	1	1	1	GD05821140	820Ω
RE04	1	1	1	1	GD05821140	820Ω
RE05	1	1	1	1	GD05392140	3.9KΩ
RE06	1	1	1	1	GD05392140	3.9KΩ
RE07	1	1	1	1	GD05682140	6.8KΩ
RE08	1	1	1	1	GD05682140	6.8KΩ
RE09	1	1	1	1	GD05682140	6.8KΩ
RE10	1	1	1	1	GD05682140	6.8KΩ

- (U): for U.S.A.
- (C): for Canada
- (N): for Europe
- (A): for Australia

REF. DESIG.	Q'TY				PART NO.	DESCRIPTION
	U	C	N	A		
RE11	1	1	1	1	GD05562140	5.6KΩ
RE12	1	1	1	1	GD05562140	5.6KΩ
RE13	1	1	1	1	GD05562140	5.6KΩ
RE14	1	1	1	1	GD05562140	5.6KΩ
RE15	1	1	1	1	GD05223140	22KΩ
RE16	1	1	1	1	GD05223140	22KΩ
RE17	1	1	1	1	GD05223140	22KΩ
RE18	1	1	1	1	GD05223140	22KΩ
RE19	1	1	1	1	GD05223140	22KΩ
RE20	1	1	1	1	GD05223140	22KΩ
RE21	1	1	1	1	GD05103140	10KΩ
RE22	1	1	1	1	GD05103140	10KΩ
RE23	1	1	1	1	GD05470140	47Ω
RE24	1	1	1	1	GD05470140	47Ω
RE25	1	1	1	1	RM01040150	100KΩ(B) Variable
RE26	1	1	1	1	RM01040150	100KΩ(B) Variable
RE27	1	1	1	1	RM01040150	100KΩ(B) Variable
PE00-SEMICONDUCTORS						
QE01	1	1	1	1	HC10003090	IC NJM4558D
QE02	1	1	1	1	HC10003090	IC NJM4558D
PE00-FILTER						
KF01	1	1	1	1	FP11070060	Ceramic Filter
PG00-VOLUME CIRCUIT BOARD						
PG00	1	1	1	1	YK21161870	P.W. Board, Volume
	1	1	1	1	ZZ21161870	P.W. Board Assembly
RG01	1	1	1	1	RQ02040030	100KΩ(B), 200KΩ(W) Variable
WG01	1	1	1	1	YU05160210	Jumper Lead
WG02	1	1	1	1	YU03115210	Jumper Lead
PK01-POWER LED METER CIRCUIT BOARD						
PK01	1	1	1	1	YN21142210	P.W. Board, Power Led Meter
	1	1	1	1	ZZ21162210	P.W. Board Assembly
QK01	1	1	1	1	HI11202320	L.E.D. GL-112R4
QK02	1	1	1	1	HI11202320	L.E.D. GL-112R4
PK02-POWER LED METER AMP. CIRCUIT BOARD						
PK02	1	1	1	1	YN21142220	P.W. Board, Power Led Meter Amp.
	1	1	1	1	ZZ21162220	P.W. Board Assembly
PK02-CAPACITORS						
CK01	1	1	1	1	EA10602530	Elect 10μF 25V
CK02	1	1	1	1	EA10602530	Elect 10μF 25V
CK03	1	1	1	1	EA10602530	Elect 10μF 25V
CK04	1	1	1	1	EA10602530	Elect 10μF 25V
CK05	1	1	1	1	EA10602530	Elect 10μF 25V
CK06	1	1	1	1	EA10602530	Elect 10μF 25V
CK07	1	1	1	1	EA10702590	Elect 100μF 25V

REF. DESIG.	Q'TY				PART NO.	DESCRIPTION
	U	C	N	A		
PK02-RESISTORS						
(All Resistors are ±5% & ¼W)						
RK01	1	1	1	1	RA02030060	20KΩ(B) Trimming
RK02	1	1	1	1	RA02030060	20KΩ(B) Trimming
RK03	1	1	1	1	GD05152140	1.5KΩ
RK04	1	1	1	1	GD05152140	1.5KΩ
RK05	1	1	1	1	GD05152140	1.5KΩ
RK06	1	1	1	1	GD05152140	1.5KΩ
RK07	1	1	1	1	GD05152140	1.5KΩ
RK08	1	1	1	1	GD05152140	1.5KΩ
RK09	1	1	1	1	GD05152140	1.5KΩ
RK10	1	1	1	1	GD05152140	1.5KΩ
RK11	1	1	1	1	GD05152140	1.5KΩ
RK12	1	1	1	1	GD05152140	1.5KΩ
RK13	1	1	1	1	GD05152140	1.5KΩ
RK14	1	1	1	1	GD05152140	1.5KΩ
RK15	1	1	1	1	GD05152140	1.5KΩ
RK16	1	1	1	1	GD05152140	1.5KΩ
RK17	1	1	1	1	GD05152140	1.5KΩ
RK18	1	1	1	1	GD05152140	1.5KΩ
RK19	1	1	1	1	GD05152140	1.5KΩ
RK20	1	1	1	1	GD05152140	1.5KΩ
RK21	1	1	1	1	GD05152140	1.5KΩ
RK22	1	1	1	1	GD05152140	1.5KΩ
RK23	1	1	1	1	GD05152140	1.5KΩ
RK24	1	1	1	1	GD05152140	1.5KΩ
RK25	1	1	1	1	GD05152140	1.5KΩ
RK26	1	1	1	1	GD05152140	1.5KΩ
RK27	1	1	1	1	GD05103140	10KΩ
RK28	1	1	1	1	GD05103140	10KΩ
RK29	1	1	1	1	GD05103140	10KΩ
RK30	1	1	1	1	GD05103140	10KΩ
RK31	1	1	1	1	GD05123140	12KΩ
RK32	1	1	1	1	GD05123140	12KΩ
RK33	1	1	1	1	GD05182140	1.8KΩ
RK34	1	1	1	1	GD05182140	1.8KΩ
RK35	1	1	1	1	GD05121140	120Ω
RK36	1	1	1	1	GD05121140	120Ω
RK37	1	1	1	1	GD05272140	2.7KΩ
RK38	1	1	1	1	GD05272140	2.7KΩ
RK39	1	1	1	1	GD05274140	270KΩ
RK40	1	1	1	1	GD05274140	270KΩ
RK41	1	1	1	1	GD05153140	15KΩ
RK42	1	1	1	1	GD05153140	15KΩ
RK44	1	1	1	1	GD05153140	15KΩ
RK45	1	1	1	1	GD05822140	8.2KΩ
RK46	1	1	1	1	GD05822140	8.2KΩ
RK47	1	1	1	1	GD05562140	5.6KΩ
RK48	1	1	1	1	GD05562140	5.6KΩ
RK49	1	1	1	1	GD05181140	180Ω
RK50	1	1	1	1	GD05181140	180Ω
RK51	1	1	1	1	GD05103140	10KΩ
RK52	1	1	1	1	GD05103140	10KΩ
RK53	1	1	1	1	GD05153140	15KΩ
RK54	1	1	1	1	GD05392140	3.9KΩ
RK55	1	1	1	1	GG05271140	270Ω

- (U): for U.S.A.
- (C): for Canada
- (N): for Europe
- (A): for Australia

REF. DESIG.	Q'TY				PART NO.	DESCRIPTION
	U	C	N	A		
PK02-SEMICONDUCTORS						
QK03	1	1	1	1	HC10002320	IC IR2418A
QK04	1	1	1	1	HC10002320	IC IR2418A
QK05	1	1	1	1	HH00008030	Thermistor SDT-1000
QK06	1	1	1	1	HH00008030	Thermistor SDT-1000
QK07	1	1	1	1	HT111272A0	Transistor 2SA1127(R or S)
QK08	1	1	1	1	HT111272A0	Transistor 2SA1127(R or S)
QK09	1	1	1	1	HT326342A0	Transistor 2SC2634(R or S)
QK10	1	1	1	1	HT326342A0	Transistor 2SC2634(R or S)
QK11	1	1	1	1	HD20011050	Diode 1S1555
QK12	1	1	1	1	HD20011050	Diode 1S1555
QK13	1	1	1	1	HD20011050	Diode 1S1555
QK14	1	1	1	1	HD20011050	Diode 1S1555
QK15	1	1	1	1	HD30059090	Zener XZ-185
PN00-VOLTAGE AMP. CIRCUIT BOARD						
PN00	1	1	1	1	YN21161820	P.W. Board, Voltage Amp.
	1	1	1	1	ZZ21161820	P.W. Board Assembly
PN00-CAPACITORS						
CN01	1	1	1	1	EA47505030	Elect 4.7 μ F 50V
CN02	1	1	1	1	EA47505030	Elect 4.7 μ F 50V
CN03	1	1	1	1	EA10505030	Elect 1 μ F 50V
CN04	1	1	1	1	EA10505030	Elect 1 μ F 50V
CN05	1	1	1	1	DD10050300	Ceramic 5pF \pm 0.25pF
CN06	1	1	1	1	DD10050300	Ceramic 5pF \pm 0.25pF
CN07	1	1	1	1	DD15270510	Ceramic 27pF \pm 5%
CN08	1	1	1	1	DD15270510	Ceramic 27pF \pm 5%
CN09	1	1	1	1	DF16332300	Film 3300pF \pm 10%
CN10	1	1	1	1	DF16332300	Film 3300pF \pm 10%
CN11	1	1	1	1	DF16332300	Film 3300pF \pm 10%
CN12	1	1	1	1	DF16332300	Film 3300pF \pm 10%
CN13	1	1	1	1	EA10706310	Elect 100 μ F 63V
CN14	1	1	1	1	EA10706310	Elect 100 μ F 63V
PN00-RESISTORS (All Resistors are \pm 5% & 1/4W)						
RN01	1	1	1	1	GD05474140	470K Ω
RN02	1	1	1	1	GD05474140	470K Ω
RN03	1	1	1	1	GD05221140	220 Ω
RN04	1	1	1	1	GD05221140	220 Ω
RN05	1	1	1	1	GD05333140	33K Ω
RN06	1	1	1	1	GD05333140	33K Ω
RN07	1	1	1	1	GD05273140	27K Ω
RN08	1	1	1	1	GD05273140	27K Ω
RN09	1	1	1	1	RA01030460	10K Ω Trimming
RN10	1	1	1	1	RA01030460	10K Ω Trimming
RN11	1	1	1	1	GD05222140	2.2K Ω
RN12	1	1	1	1	GD05222140	2.2K Ω
RN13	1	1	1	1	GD05683140	68K Ω
RN14	1	1	1	1	GD05683140	68K Ω
RN15	1	1	1	1	GG05332140	3.3K Ω
RN16	1	1	1	1	GG05332140	3.3K Ω
RN17	1	1	1	1	GD05333140	33K Ω
RN18	1	1	1	1	GD05333140	33K Ω
RN19	1	1	1	1	GG05332140	3.3K Ω
RN20	1	1	1	1	GG05332140	3.3K Ω

REF. DESIG.	Q'TY				PART NO.	DESCRIPTION
	U	C	N	A		
RN21	1	1	1	1	GD05331140	330 Ω
RN22	1	1	1	1	GD05331140	330 Ω
RN23	1	1	1	1	GD05331140	330 Ω
RN24	1	1	1	1	GD05331140	330 Ω
RN25	1	1	1	1	GG05101140	100 Ω
RN26	1	1	1	1	GG05101140	100 Ω
RN27	1	1	1	1	GD05100140	10 Ω
RN28	1	1	1	1	GD05100140	10 Ω
RN29	1	1	1	1	GD05223140	22K Ω
RN30	1	1	1	1	GD05223140	22K Ω
PN00-SEMICONDUCTORS						
QN01	1	1	1	1	HD20011050	Diode 1S1555
QN02	1	1	1	1	HD20011050	Diode 1S1555
QN03	1	1	1	1	HD20011050	Diode 1S1555
QN04	1	1	1	1	HD20011050	Diode 1S1555
QN05	1	1	1	1	HT309451Q0	Transistor 2SC945(Q)
QN06	1	1	1	1	HT309451Q0	Transistor 2SC945(Q)
QN07	1	1	1	1	HT107331Q0	Transistor 2SA733(Q)
QN08	1	1	1	1	HT107331Q0	Transistor 2SA733(Q)
QN09	1	1	1	1	HD20011050	Diode 1S1555
QN10	1	1	1	1	HD20011050	Diode 1S1555
QN11	1	1	1	1	HD20011050	Diode 1S1555
QN12	1	1	1	1	HD20011050	Diode 1S1555
QN13	1	1	1	1	HC10032030	IC STK-3082
PN00-PLUG						
JN01	1	1	1	1	YP06000600	Plug
JN02	1	1	1	1	YP06000600	Plug
PS00-SWITCH CIRCUIT BOARD						
PS00	1	1	1	1	YK21161860	P.W. Board, Switch
	1	1	1	1	ZZ21161860	P.W. Board Assembly
PS00-CAPACITORS						
CS01	1	1	1	1	DF15472300	Film 4700pF \pm 5%
CS02	1	1	1	1	DF15472300	Film 4700pF \pm 5%
CS03	1	1	1	1	DK16271300	Ceramic 270pF \pm 10%
CS04	1	1	1	1	DK16271300	Ceramic 270pF \pm 10%
CS05	1	1	1	1	EA47405030	Elect 0.47 μ F 50V
CS06	1	1	1	1	EA47405030	Elect 0.47 μ F 50V
CS07	1	1	1	1	DF16473300	Film 0.047 μ F \pm 10%
CS08	1	1	1	1	DF16473300	Film 0.047 μ F \pm 10%
CS09	1	1	1	1	DK16681300	Ceramic 680pF \pm 10%
CS10	1	1	1	1	DK16681300	Ceramic 680pF \pm 10%
PS00-RESISTORS (All Resistors are \pm 5% & 1/4W)						
RS01	1	1	1	1	GD05564140	560K Ω
RS02	1	1	1	1	GD05564140	560K Ω
RS03	1	1	1	1	GD05104140	100K Ω
RS04	1	1	1	1	GD05104140	100K Ω
RS05	1	1	1	1	GD05392140	3.9K Ω
RS06	1	1	1	1	GD05392140	3.9K Ω
RS07	1	1	1	1	GD05473140	47K Ω
RS08	1	1	1	1	GD05473140	47K Ω
RS09	1	1	1	1	GD05682140	6.8K Ω
RS10	1	1	1	1	GD05682140	6.8K Ω

- (U): for U.S.A.
- (C): for Canada
- (N): for Europe
- (A): for Australia

REF. DESIG.	Q'TY				PART NO.	DESCRIPTION
	U	C	N	A		
RS11	1	1	1	1	GD05222140	2.2K Ω
RS12	1	1	1	1	GD05222140	2.2K Ω
RS13	1	1	1	1	GD05103140	10K Ω
RS15	1	1	1	1	GD05273140	27K Ω
RS16	1	1	1	1	GD05273140	27K Ω
RS17	1	1	1	1	GD05154140	150K Ω
PS00-MISCELLANEOUS						
JS04	1	1	1	1	YP06001040	Plug (3P)
SS01	1	1	1	1	SP04060100	Push Switch
PT00-SPEAKER SWITCH CIRCUIT BOARD						
PT00	1	1	1	1	YK21161830	P.W. Board, Speaker Switch
	1	1	1	1	ZZ21161830	P.W. Board Assembly
PT00-RESISTORS						
RT01	1	1	1	1	GP05331030	330 Ω \pm 5% 3W
RT02	1	1	1	1	GP05331030	330 Ω \pm 5% 3W
PT00-SWITCH						
ST01	1	1	1	1	SP04020200	Push Switch, Speaker
PV00-TAPE INPUT CIRCUIT BOARD						
PV00	1	1	1	1	YK21161720	P.W. Board, Tape Input
	1	1	1	1	ZZ21161720	P.W. Board Assembly
JV11	1	1	1	1	YT02040280	Terminal, Tape 1 IN/Out
WV01	1	1	1	1	YU07060210	Jumper Lead
PW00-HEADPHONE CIRCUIT BOARD						
PW00	1	1	1	1	YK21161840	P.W. Board, Headphone
	1	1	1	1	ZZ21161840	P.W. Board Assembly
JW01	1	1	1	1	YJ01001340	Jack, Headphone
PX00-METER CIRCUIT BOARD						
PX00	1	1	1	1	YK21161750	P.W. Board, Meter
MX01	1	1	1	1	IM11000010	D.C. Meter, Center
MX02	1	1	1	1	IM11000020	D.C. Meter, Signal

REF. DESIG.	Q'TY				PART NO.	DESCRIPTION
	U	C	N	A		
PY00-STEREO LED CIRCUIT BOARD						
PY00	1	1	1	1	YK21161740	P.W. Board, Stereo Led
	1	1	1	1	ZZ21161740	P.W. Board Assembly
QY01	1	1	1	1	HI10009020	L.E.D. LN26RPLCF
PZ00-DIAL POINTER LAMP						
PZ00	1	1	1	1	YK21161730	P.W. Board, Dial Pointer Lamp
	1	1	1	1	YK21161730	P.W. Board Assembly
JZ01	1	1	1	1	YP10001200	Plug
JZ02	1	1	1	1	YP10001200	Plug
Δ MZ01	1	1	1	1	IN10080460	Lamp 100mA 8V

(W01-99)	Assembly and Wiring
(T01-99)	Adjustment
(X01-00)	Correction

7. TECHNICAL SPECIFICATIONS

[FOR U.S.A. & CANADA]

AMPLIFIER SECTION

RATED POWER OUTPUT, MINIMUM CONTINUOUS AVERAGE POWER PER CHANNEL, BOTH CHANNELS DRIVEN		88 W
POWER BAND	20 Hz to 20 kHz	
TOTAL HARMONIC DISTORTION		0.05%
LOAD IMPEDANCE		4 OHMS
RATED POWER OUTPUT, MINIMUM CONTINUOUS AVERAGE POWER PER CHANNEL, BOTH CHANNELS DRIVEN		70 W
POWER BAND	20 Hz to 20 kHz	
TOTAL HARMONIC DISTORTION		0.025%
LOAD IMPEDANCE		8 OHMS

I.M. Distortion

(I.H.F. method, 60 Hz and 7 kHz mixed 4:1 at rated power output)

at 8 ohm load impedance	0.025%
at 4 ohm load impedance	0.05%
Damping Factor (at 20 Hz)	50

PREAMPLIFIER SECTION

Phono

Input Overload at 1 kHz	225 mV
Equivalent Input Noise ("A" Weighted)	0.1 μ V
Dynamic Range (Dynamic Range is the ratio of input overload to equivalent input noise)	127 dB
Input Sensitivity	2.7 mV
Input Impedance	47 kohms
Input Capacitance	100 pF
Frequency Response, RIAA 20 Hz to 20 kHz	\pm 0.2 dB
Signal-to-Noise Ratio ("A" Weighted) (at rated output and 10 mV input)	90 dB
High Level (Aux and Tape)	
Input Sensitivity	160 mV
Input Impedance	20 kohms
Frequency Response (includes power amp)	10 Hz to 70 kHz \pm 1.0 dB
Signal-to-Noise Ratio ("A" Weighted) (ref. to rated output and 775 mV input)	98 dB
Output Levels	
Tape Out (ref. 10 mV at Phone inputs)	580 mV
Output Impedance	
Tape Out	500 ohms

FM TUNER SECTION

Sensitivity

IHF Usable	9.8 dBf (1.7 μ V)
IHF 50 dB Quieting (Mono)	13.2 dBf (2.5 μ V)
(Stereo)	36.1 dBf (38 μ V)

Quieting Slope (Mono)

RF Input for 30 dB Quieting	7.2 dBf (1.3 μ V)
Quieting at:	
20 dBf (5.5 μ V)	55 dB
25 dBf (10 μ V)	60 dB
40 dBf (55 μ V)	74 dB
65 dBf (1000 μ V)	80 dB

Quieting Slope (Stereo)	
Quieting at:	
30 dBf (17 μ V)	42 dB
40 dBf (55 μ V)	54 dB
50 dBf (173 μ V)	64 dB
65 dBf (1000 μ V)	72 dB
Distortion (Mono) at 65 dBf (1000 μ V)	
100 Hz	0.2%
1000 Hz	0.2%
6000 Hz	0.3%
Distortion (Stereo) at 65 dBf (1000 μ V)	
100 Hz	0.3%
1000 Hz	0.25%
6000 Hz	0.4%
Frequency Response	
30 Hz to 15 kHz	
Mono and Stereo	+0.5 dB, -1.0 dB
Capture Ratio at 65 dBf (1000 μ V)	1.0 dB
Alternate Channel Selectivity	65 dB
Spurious Response Rejection	90 dB
Image Response Rejection	55 dB
I.F. Rejection (Balanced)	90 dB
A.M. Suppression	55 dB
Stereo Separation at 1 kHz	45 dB
Subcarrier Rejection	65 dB

AM TUNER SECTION

IHF Usable Sensitivity	20 μ V
Signal-to-Noise Ratio	50 dB
Alternate Channel Selectivity	45 dB
Image Rejection	45 dB
Spurious Response Rejection	55 dB
I.F. Rejection	40 dB

GENERAL

Power Requirements	120 VAC, 60 Hz
Power Consumption at rated output, both channels operating	300 W
Idling Power (Volume Control at zero)	28 W
Dimensions:	
Panel Width	466 mm (18-3/8")
Panel Height	140 mm (5-1/2")
Depth	353 mm (13-7/8")
Weight:	
Unit alone	11 kg (24.2 lbs)
Packed for Shipment	13 kg (28.6 lbs)

[FOR EUROPE]

AUDIO SECTION

POWER OUTPUT, DIN, 4 OHM, PER CHANNEL				129 W
POWER OUTPUT, FTC AMERICAN STANDARDS, 4 OHM, PER CHANNEL				88 W
TOTAL HARMONIC DISTORTION AT RATED POWER OUTPUT				0.06%
I.M. DISTORTION AT RATED POWER OUTPUT				
(250 Hz AND 8 kHz MIXED, AMPLITUDE RATIO 4:1)				0.06%
POWER OUTPUT, DIN, 8 OHM, PER CHANNEL				91 W
POWER OUTPUT, FTC AMERICAN STANDARDS, 8 OHM, PER CHANNEL				70 W
TOTAL HARMONIC DISTORTION AT RATED POWER OUTPUT				0.03%
I.M. DISTORTION AT RATED POWER OUTPUT				
(250 Hz AND 8 kHz MIXED, AMPLITUDE RATIO 4:1)				0.03%
POWER BANDWIDTH			10 Hz ~ 40 kHz	
		(40 Hz)	(1 kHz)	(12.5 kHz)
DAMPING FACTOR 8 OHM	65	65		60
Frequency Response				
Phono (RIAA)				±0.5 dB
Aux (±1 dB)				18 Hz ~ 40 kHz
Signal-to-Noise Ratio				
Phono				72 dB
Aux				80 dB
Input Terminals				
Phono: Input Impedance				47 k ohms
Input Capacitance				100 pF
Input Sensitivity				2.7 mV
Overload Margin				40 dB
Aux: Input Impedance				20 k ohms
Input Sensitivity				160 mV
Phono Equivalent Input Noise				1.2 μV
Phono Dynamic Range (Ratio of input overload to equivalent input noise)				107 dB
Channel Balance (0 to -40 dB/40 Hz ~ 16 kHz)				
Phono				2.0 dB
Aux				1.5 dB
Interchannel Crosstalk				
Phono 1 kHz				35 dB
Aux 1 kHz				50 dB
Tape 1 kHz				50 dB
Intersource Crosstalk (Worst Point)				
1 kHz				50 dB
Output Voltage, 1 kHz				
Tape Out				450 mV
Output Impedance, 1 kHz				
Tape Out				500 ohms
Headphone Jack Load Impedance				8 ohms

FM TUNER SECTION

Frequency Range	87.5 ~ 108 MHz
Usable Sensitivity 40 kHz Deviation, 98 MHz	
Mono, S/N 26 dB	1.4 μV
Stereo, S/N 46 dB	42 μV
Alternate Channel Selectivity, 98 MHz±300 kHz	36 dB
Image Response Rejection, 98 MHz	54 dB
IF Rejection, 98 MHz	100 dB
Spurious Response Rejection, 98 MHz	95 dB
AM Suppression, 98 MHz	60 dB

Signal-to-Noise Ratio, 98 MHz		
Unweighted:	Mono	72 dB
	Stereo	65 dB
Weighted:	Mono	62 dB
	Stereo	55 dB
Pilot Signal & Subcarrier Rejection		
	19 kHz	60 dB
	38 kHz	65 dB
Total Harmonic Distortion, 98 MHz		
	Mono	0.08%
	Stereo	0.15%
Frequency Response		
	30 Hz ~ 15 kHz	+0.3 dB, -1.0 dB
Separation		
	Stereo	47 dB
Channel Balance		0.5 dB
Output Voltage, 1 kHz		600 mV
Output Impedance, 1 kHz		1 k ohms
Acceptable Load Impedance, 1 kHz		47 k ohms
Antenna Terminals		
	Balanced	300 ohms
	Unbalanced	75 ohms

AM TUNER SECTION

Frequency Range	515 ~ 1650 kHz
Usable Sensitivity (26 dB S/N 30% Mod., 1 MHz)	15 μ V
Selectivity, 1 kHz \pm 9 kHz	26 dB
Image Rejection, 1 MHz	50 dB
IF Rejection, 1 MHz	40 dB
Spurious Response Rejection, 1 MHz	46 dB
Signal-to-Noise Ratio, 1 MHz	44 dB
Frequency Response, 1 MHz \pm 3 dB	35 Hz ~ 1.8 kHz
Total Harmonic Distortion, 1 MHz	0.8%

GENERAL

Power Requirements	220 V AC, 50 Hz
	(N version is featuring an external voltage selector for use on 110 V. Other versions can be converted by a qualified technician to operate on 240 V.)
Power Consumption at Rated Output, Both Channels Operating	300 W
Idling Power	28 W
Semiconductor Complement	
Integrated Circuits	12
Transistors	29
Diodes	39
Field Effect Transistors	1
Dimensions	
Panel Width	18-3/8" (466 mm)
Panel Height	5-1/2" (140 mm)
Depth	13-7/8" (353 mm)
Weight	
Unit alone	26.4 lbs (12 kg)
Packed for shipment	30.8 lbs (14 kg)